

AgriCAD TF24C

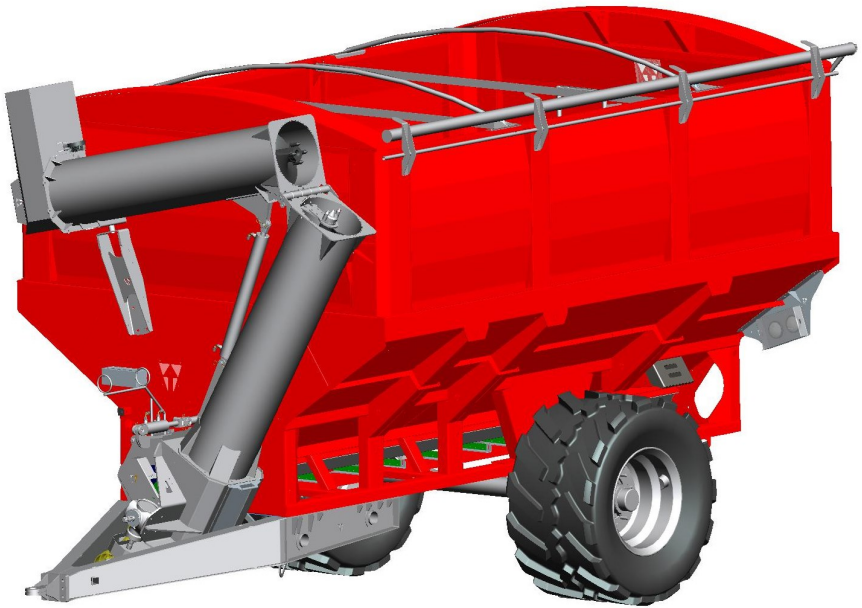

Owners Manual

Introduction

1. Foreword

Before operating the implement, read and strictly comply with the operating instructions. In doing so, you will avoid accidents, reduce repair costs and downtime and increase the reliability and service life of your implement. Pay attention to the safety instructions! AgriCAD will not assume liability for any damage or malfunctions resulting from failure to comply with the operating instructions.

These operating instructions will assist you in getting to know your implement and in using it correctly for its intended purposes. The operating instructions must be read and strictly adhered to by all persons working on or with the implement.

e.g. Operation (including preparation, fault rectification during work and servicing)

Maintenance (maintenance and inspection)

Transport

We reserve the right to alter illustrations as well as technical data and weights contained in these operating instructions for the purpose of improving the implement without notice.

2. Warranty claims

This implement carries a one year warranty on parts and workmanship.

Wear parts are not covered by this warranty.

3. Intended use

The implement was built in accordance with latest technical standards and generally accepted safety regulations. However, risks of injury to the operator or third parties and impairment of the implement or other tangible assets can occur during use.

The implement must only be operated for its intended use if in a technically good condition, whilst being aware of safety and risks and in strict compliance with the operating instructions!

Faults, particularly those which impair safety, must be remedied immediately. The implement must only be operated, serviced and repaired by persons who are familiar with it and have been made aware of the dangers involved.

Genuine spare parts and accessories from AgriCAD are available for this implement. Spare parts and accessories which are not supplied by AgriCAD, have not been tested or approved by AgriCAD. Installation or use of non-original AgriCAD products may have a detrimental effect on specific design features of the implement and impair the safety of implement operators and the implement itself. AgriCAD will not assume liability whatsoever for damage resulting from the use of non-original parts and accessories.

The implement was designed for the transfer of grain in a agricultural application. Any other use beyond this limits, e.g. as a means of transport, is deemed improper.

AgriCAD will not assume liability whatsoever for damage resulting from unintended use. The risk will be borne solely by the user.

Intended use also includes the strict compliance with the operating instructions specified by the AgriCAD.

3.1 Consequential damage

The implement was manufactured by AgriCAD with great care. Nevertheless, even when used properly, malfunctions or complete failure may be caused by e.g.:

Blockage or seed bridging (i.e. caused by foreign bodies or moist seed)

Excessive wear due to the failing of a wear parts. (i.e. Damage on auger resulting from bearing failure)

Damage caused by external influences.

Incorrect or inappropriate drive speeds and travel speeds.

Incorrect operation of the implement.

You should therefore check the correct function of your implement before and during each use. Liability for consequential damages caused by operating faults is excluded.

3.2 Authorised operators

Operators must be at least 16 years of age.

The operator is responsible for third parties in the operating area.

Only those persons who have been authorised and instructed by the owner may operate the implement.

The owner must:

Make the operating instructions available to the operator.

Ensure that the operator understood the operating instructions.

The operating instructions are an integral part of the implement.

Safety and accident prevention

The following warnings and safety instructions apply to all sections in these operating instructions.

Example of Safety symbols

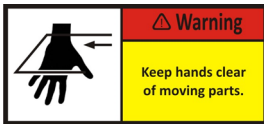

Example of Operational Symbols

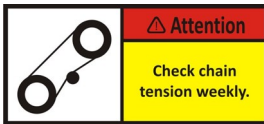

Operational safety

All protective features and safety equipment, such as detachable protective devices, must be correctly in place and reliably functioning before the implement is put into operation.

Check and tighten nuts and bolts at regular intervals.

Check tyre pressure regularly.

In case of malfunctions immediately stop and secure the implement.

Road traffic safety

This implement was manufactured as an agricultural implement and must only be used as an implement on the public roads.

Passengers are strictly forbidden to ride in or on the implement!

Hitching / unhitching

There is a risk of injury to persons when hitching/un-hitching the implement to the drawbar of the tractor.

Only park the implement on a firm and level surface.

Take special care when reversing the tractor.

Never stand between tractor and implement hitch.

Service and maintenance

Ensure that regular inspections are always carried out.

Prior to performing maintenance and servicing work, ensure that the implement is positioned on firm, level ground.

Before cleaning the implement with high pressure cleaning equipment cover all openings, which should stay clear of water, steam or cleaning agents for reasons of safety or operation.

Do not aim the water jet directly at electrical or electronic components.

Prior to working on the electrical system, disconnect it from the tractor.

Re-tighten bolted connections which have been loosened during servicing and maintenance work.

Take caution when washing with steam-jet or high pressure washers as parts of the implement can be damaged by high pressure washers.

Hydraulic connections

Do not connect hydraulic lines to the tractor, before both hydraulic systems (implement and tractor) are de-pressurised.

The hydraulic system is under high pressure. Check all lines, hoses and screwed connections regularly for leaks and any visible external damage.

After cleaning, check all hydraulic lines for leaks and loose connections.

Check hoses for chafing and signs of other damage.

The hydraulic connections between the tractor and implement are colour-coded in order to exclude operating errors.

In operation

Check the area around the implement for unauthorised persons before setting off and starting operation of the implement.

No persons should be in the operating range or when opening or closing augers.

Do not remove any of the mandatory and supplied protective devices.

Stay clear of the operating range of hydraulically operated parts.

Use access steps and treads only at standstill.

Passengers are not allowed to ride on or in the implement during operation!

PTO Shaft

Install the PTO shaft only with the engine stopped and the PTO-shaft switched off.

Use only PTO shafts with proper safety protections!

The PTO shaft locks must click into place.

The PTO shaft length must be checked for each tractor before the implement can be used.

The PTO shaft is cut to length in the factory but must be checked with each tractor used.

PTO shafts as well as shear bolt clutches depend on equipment and power. These items must never be replaced by other equipment.

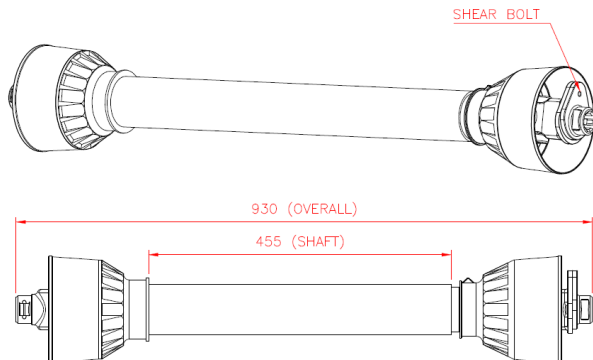

Technical data

Dimensions and weights

Width:2.99 m
 Height:.....3.40 m
 Height with auger:.....4.80 m
 Length:6.45 m
 Tare:3660 kg
 GVM:23660 kg

Standard design

Payload:.....19600 kg
 Foldable Auger ø:400 mm
 Maximum PTO speed:540 rpm
 Maximum discharge rate:.....5 t/min
 Tyres:.....710/55 R26.5
 Tyre pressure:.....4 bar
 Maximum speed with full load:15km/h

Minimum tractor specification

Minimum tractor power required:80 kW.
 Minimum hydraulic flow rate:40 l/min
 Hydraulic ports:3 double acting
 1 x double acting:Folding of auger.
 1 x double acting:Auger gate.
 1 x double acting:Bottom dump.

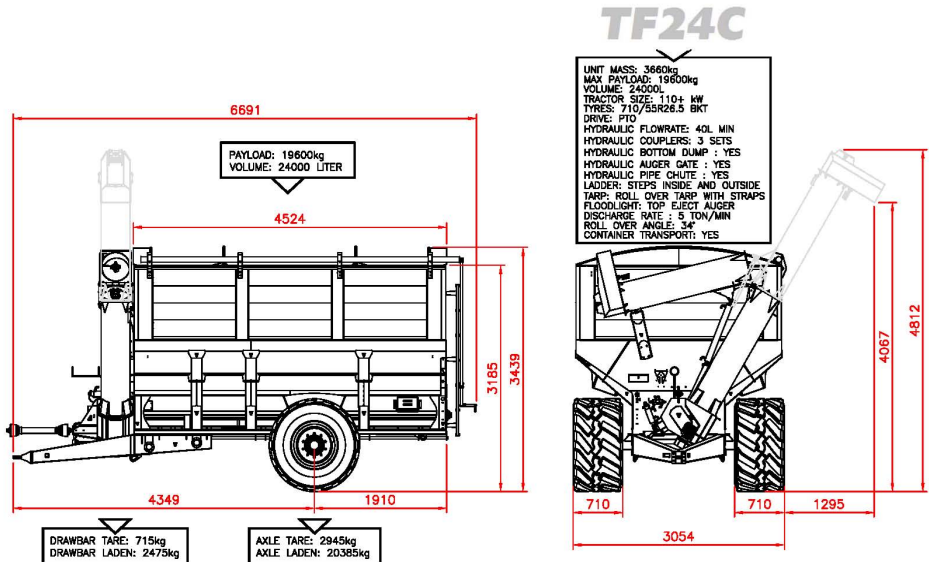

Operating instructions

Load bearing capacity of tyres

Attention!
Refer to Safety and accident prevention

When filling to maximum payload (maximum load bearing capacity), the tyres must be inflated to 4.0 bar.

Check the air pressure regularly, preferably every day.

Under-inflating of the tyres may cause damage to the tyres and rims.

When operating with maximum payload only travel at speeds below 15km/h.

Hitching the implement

Attention!

When fully loaded, the drawbar will have a load of 1500kg.

Check the tractor manufactory specification.

Sirius injury may occur if the maximum load is exceeded.

Hitch the implement to the tractor.

Wind up the landing leg and store it on the support bracket on the implement.

Connect PTO shaft to tractor. Use only manufactured specified PTO shaft.

Connect quick coupling hydraulic hoses and electric 7 pin trailer connector.

Hydraulic couplings are colour-coded in order to avoid wrong connections.

Route electric cable and hydraulic hoses in a manner that will not be damaged during operation.
(e.g. when turning)

MAXIMUM 20°

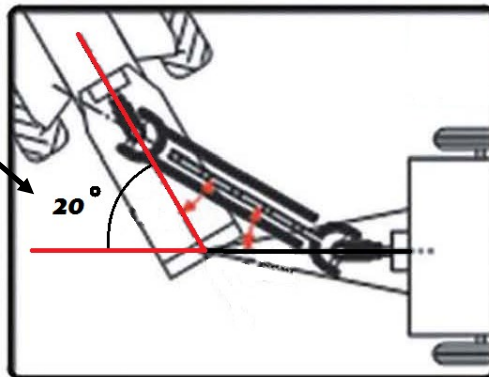

**DO NOT EXCEED THE MAXIMUM 20°
WHEN IN OPERATION**

Coupling of hydraulic system.

Attention!
No persons should be in the operating range of the working auger - open or closed

Connecting hydraulic hoses to the tractor.

Hydraulic couplings are colour-coded in order to avoid wrong connections

1 x double acting:Folding of auger (Blue).

1 x double acting:Auger gate (Red).

1 x double acting:Bottom dump (Yellow).

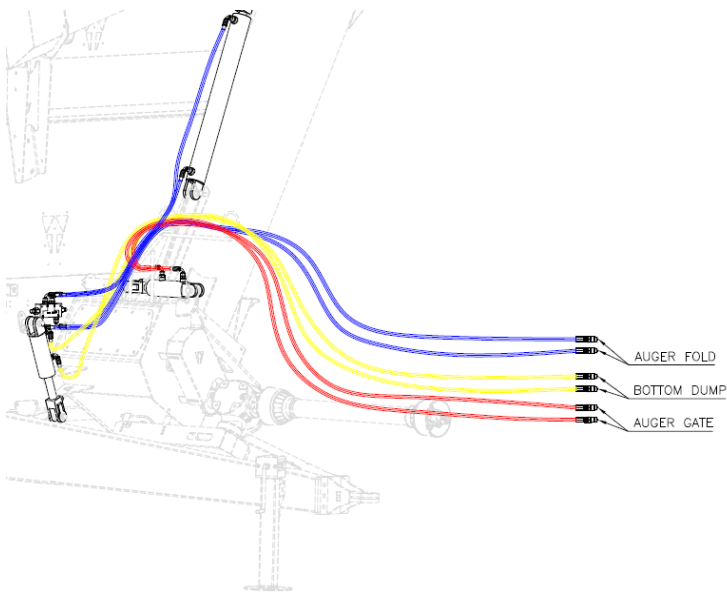

Attention!
NOTE* PLEASE CHECK WHEEL NUTS REGULARLY.

Filling chaser bin with grain.

Attention!

No person should stand in the hopper when filling with grain.

For filling with harvester while standing still.

With auger closed.

Gate must be closed.

Slowly move the chaser bin under the eject auger of the harvester.

Start filling from the front, evenly distributing the load through the chaser bin.

Stop filling when the bin is full, by monitoring top window visible from the tractor.

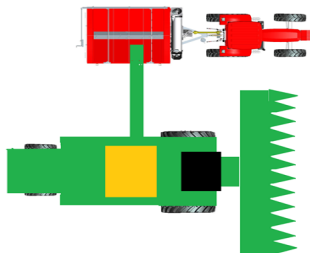

For filling with harvester while moving in field.

With auger closed.

Gate must be closed.

Driving at the same speed as the harvester.

Keep a safe distance from the moving harvester.

Move the chaser bin under the eject auger of the harvester.

Start filling from the front, evenly distributing the load through the chaser bin.

Stop filling when the bin is full, by monitoring top window visible from tractor.

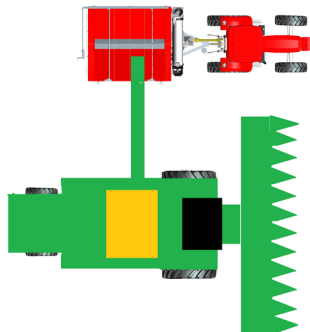

Moving chaser bin with maximum payload.

Auger must be closed.

When operating with maximum payload only travel at speeds below 15km/h.

Slow down when turning.

Discharging grain from the chaser bin.

Attention!

***Do not open or close the auger while the tractor's PTO is engaged!
There is a danger of electric shock when working with an unfolded auger,
be aware of any overhead power lines!***

Move to the unloading point to discharge.

Open the eject auger up against the end stop.

Start the PTO.

The auger can be operated with a speed of up to 540 rpm.

With increased tractor speed slowly open the gate valve.

When the emptying process is finished or the bin is empty close the gate valve.

Stop the PTO after a short continuation of running the auger,

for all grain to be ejected from the eject auger.

Fold the auger back into the closed position.

For road travel the eject auger must be folded into the closed position.

Auger light will work in conjunction with tractor park lights for night operations.

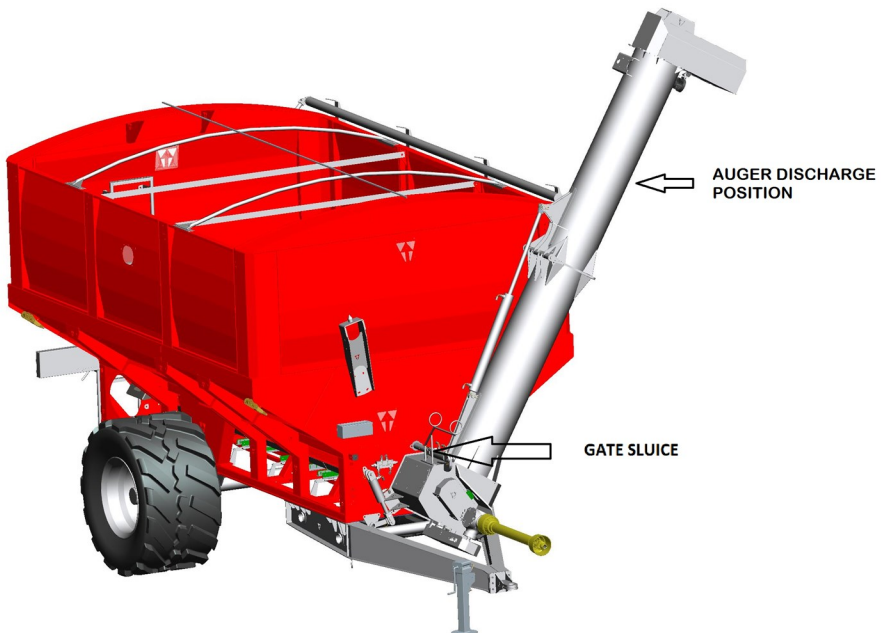

Adjusting discharge rate of Grain

The rate of grain discharged from the eject auger can be adjusted by means of the following:

By increasing or decreasing tractor rpm. Do not exceed 540rpm.

By hydraulically adjusting the bottom auger gate. (Gate Sluice)

Bin emptying using bottom dump.

The implement can be emptied over a pit with the bottom dump.
Drive to the unloading point to empty the bin.
Open the gate valve with the control unit.
Open the bottom dump with the control unit.
Close the bottom dump with the control unit after emptying the bin.
Keep hands clear at all time.

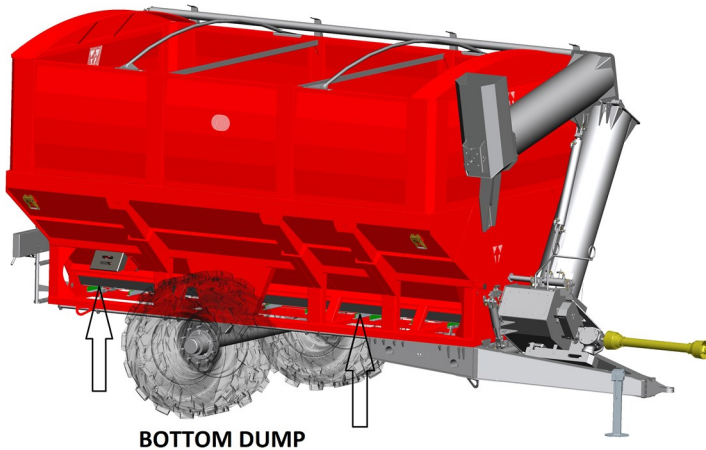

Cleaning the bin using the bottom dump

Residues inside the bin can be removed through opening the bottom dump sluice.
For this purpose drive the hopper to a point of choice and open bottom dump sluice.
All or most of the excess residue will fall free from the bin.

Cleaning the grain box

For cleaning or residue emptying it may be necessary to access the grain box.
The PTO must not be started when opening the grain box!
Switch off the tractor and remove the key from the ignition.
Disconnect PTO shaft from tractor.
Remove safety pin at bottom of grain box and slide gate upwards.
Close after use and replace safety pin.

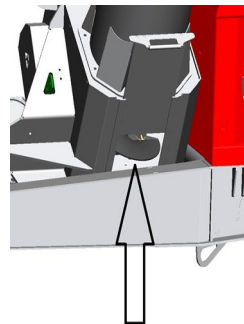

Sluice

Tarpaulin

**The chaser bin is equipped with a tarpaulin to cover the transported grain.
The tarpaulin protects the transported grain against water and other elements.**

The tarpaulin is rolled over the bin by means of the roller crank handle.
For this purpose remove the roller crank handle from the stored position.
Turning the crank handle to the left to close and to the right to open.
Straps and ratchets is fitted and can be used to tighten the tarpaulin for better protection in windy conditions.
When the crank handle is not in use, it must be locked in place by means of the lock pin supplied.

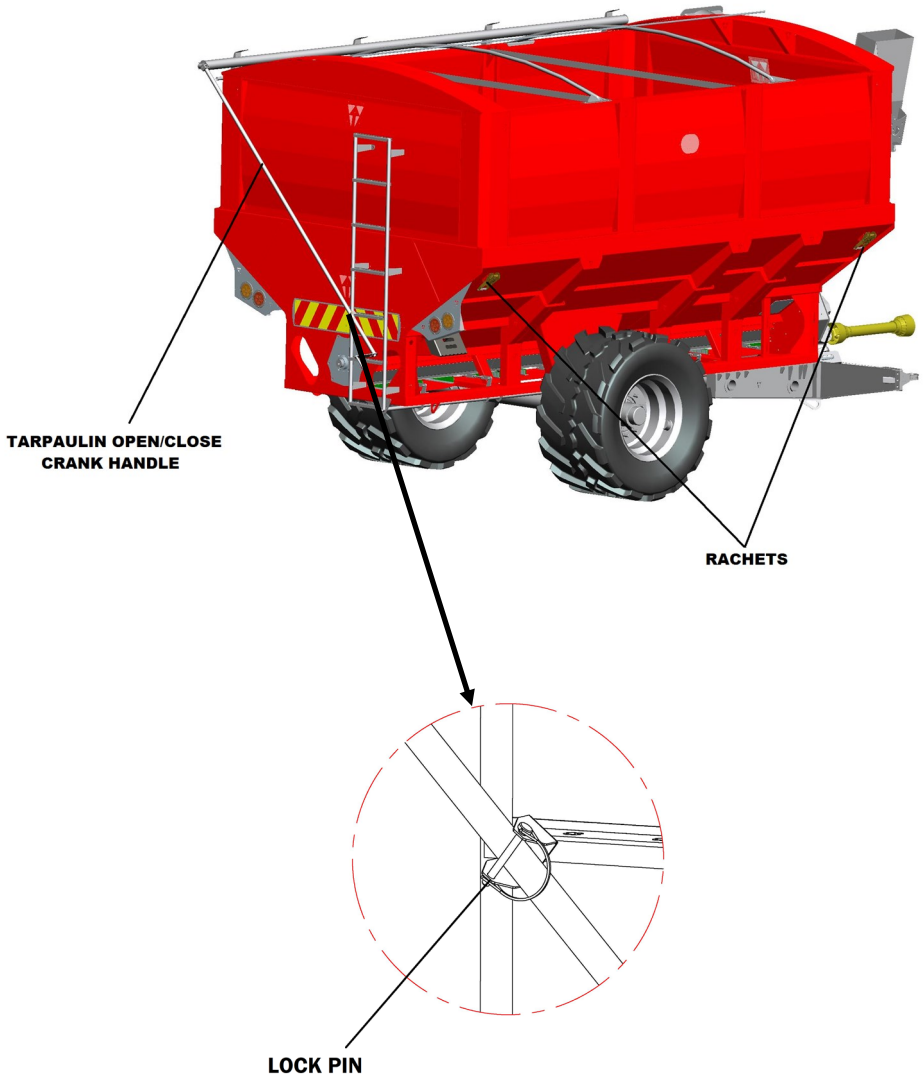

Service.

Daily / regularly inspection of shear bolts is important.
Use the correct length shear bolt.

Storing.

Storing & Parking the chaser bin

The Chaser bin should be parked under a roof so that no moisture can accumulate in the hopper.
Park the implement on level and solid ground.
When parked for longer periods, it is recommended to open the auger sluice.
Move the landing leg from its storage position on the implement and extend it.
Disconnect hydraulic and electrical connections and hook into provided storage holders.
Take care to protect the implement against pest animals like rodents, mice and rats.

Cleaning

The recommended cleaning and maintenance work should be carried out at regular intervals in order to maintain operational reliability and guarantee optimum performance.
The hydraulic cylinders, bearings and stickers should not be cleaned with a high-pressure cleaner or direct water jet. The seals and bearings are not waterproof under high pressure.

Serial Number Label.

The implement serial number is indicated on the plate(see the example at the bottom).
This information is useful when inquiring implement spare parts.

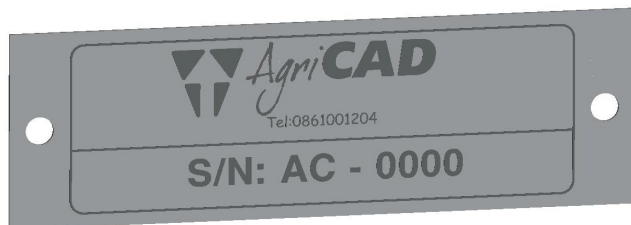

CAT 4 TOW EYE

This implement is supplied with a CAT4 tow eye but supplied with a bush that is stored in the tool box that can convert the tow eye to a CAT3

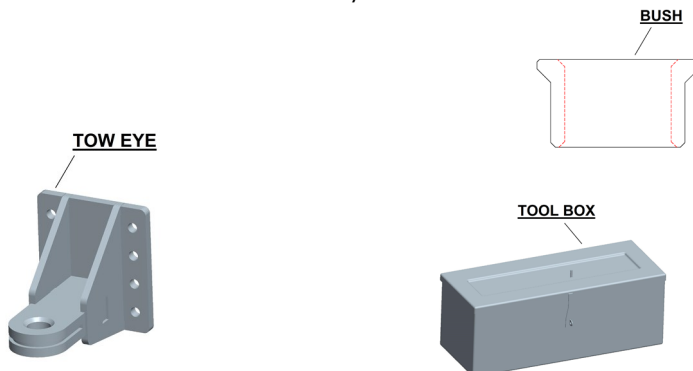

Lubricating The Chaser bin

The implement should be lubricated regularly and after every pressure wash. This ensures operational reliability and reduces the costs of repair work and down times.

Lubricate chain regularly.

Grease bearings as necessary.

Do not over grease bearings.

Approximately oil quantity 1Lt for gear box.

To check the gearbox oil level , open the plug and use cable tie for a example to check the level in the gear box.

Lubrication points

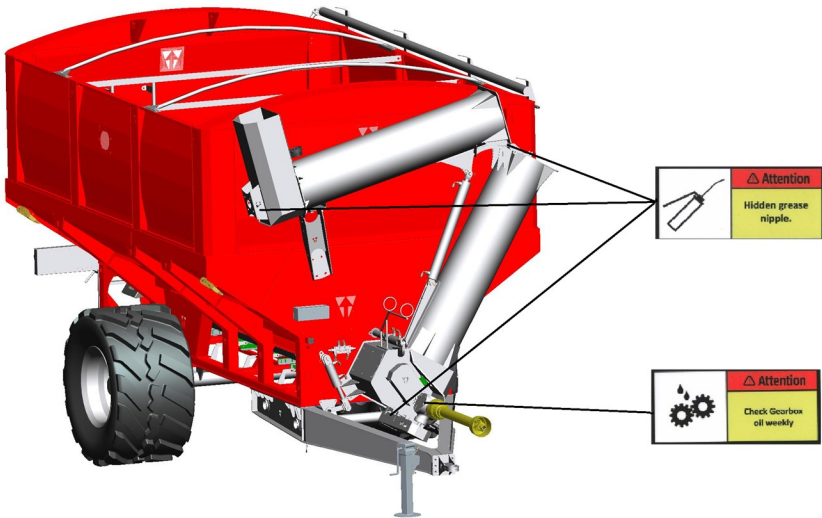

GEAR BOX

Approximately oil quantity 1Lt for gear box.

To check the gearbox oil level, open the plug on the side of the gear box (see Figure 1.1 below) and use for example a cable tie to check the oil level in the gear box. From the plug end in a down words direction the oil must be 30mm From the plug. See figure 1.2 below.

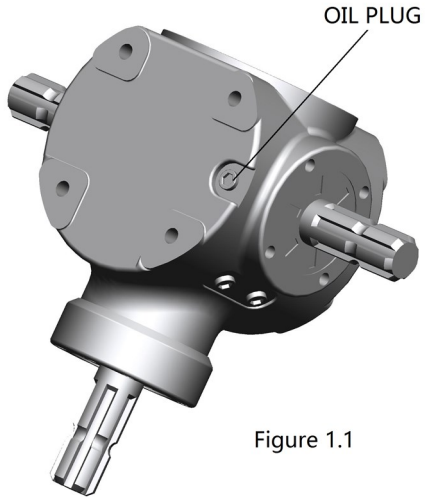

Figure 1.1

NOTE* FOR EXAMPLE USE A CABLE TIE TO MEASURE THE OIL LEVEL

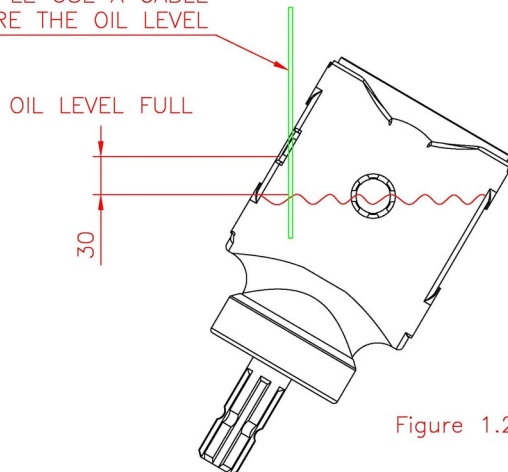
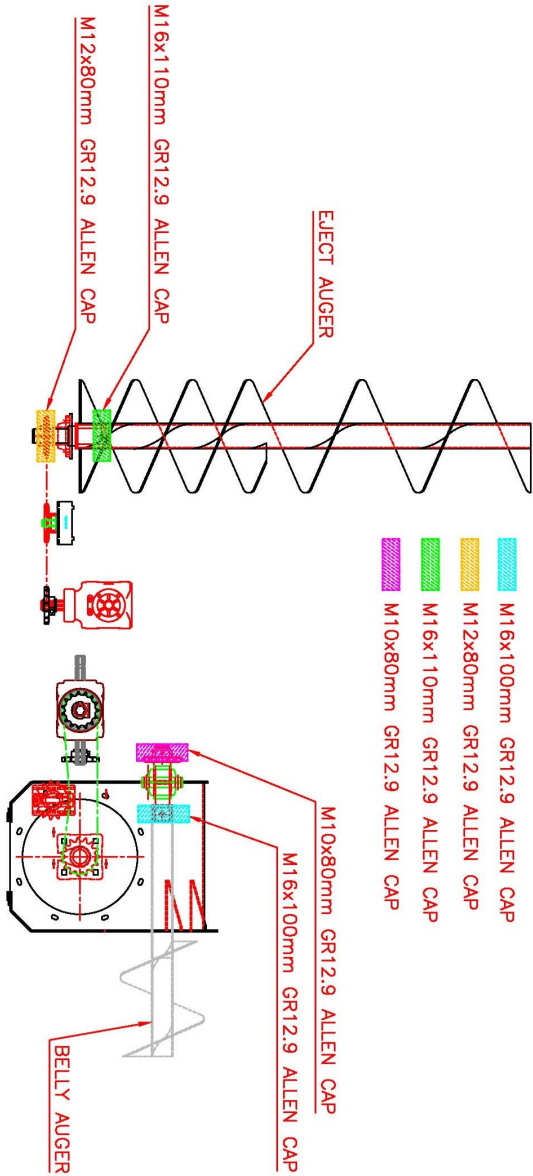

Figure 1.2

Shear bolt

Extra shear bolts supplied in toolbox.
M10x80mm 12.9 GR Allen Cap x 2



TF24C-FF-01 Main Assembly.

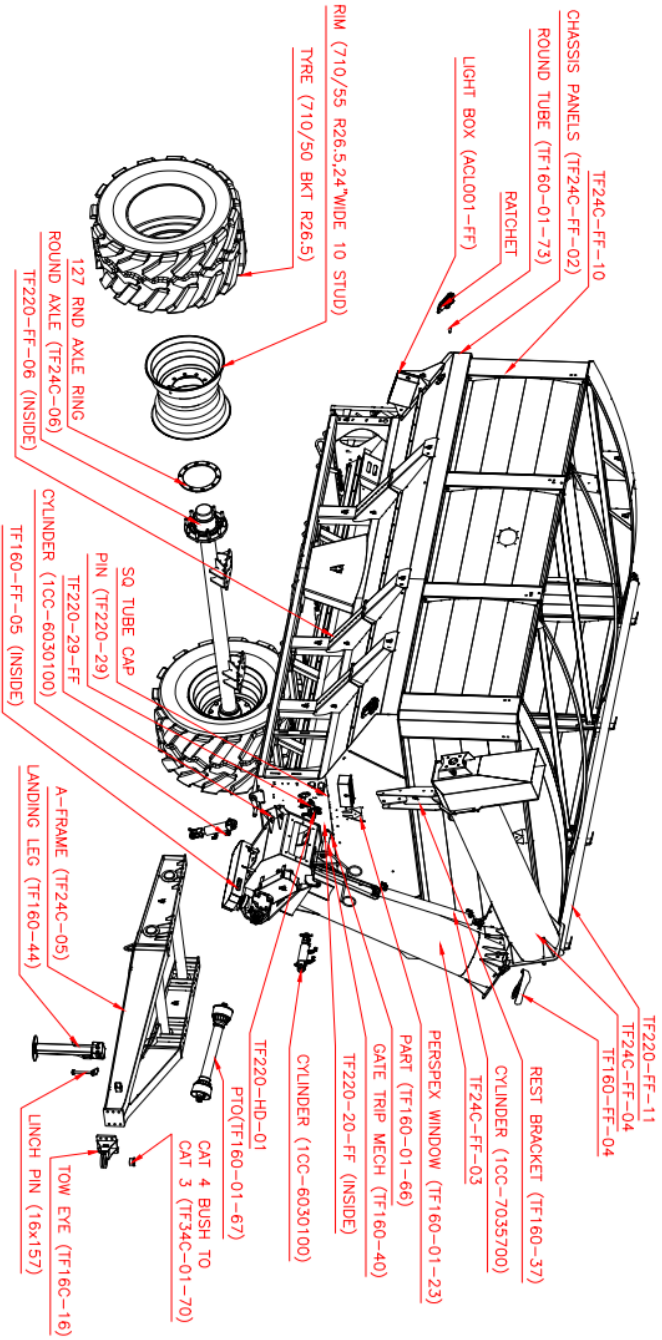

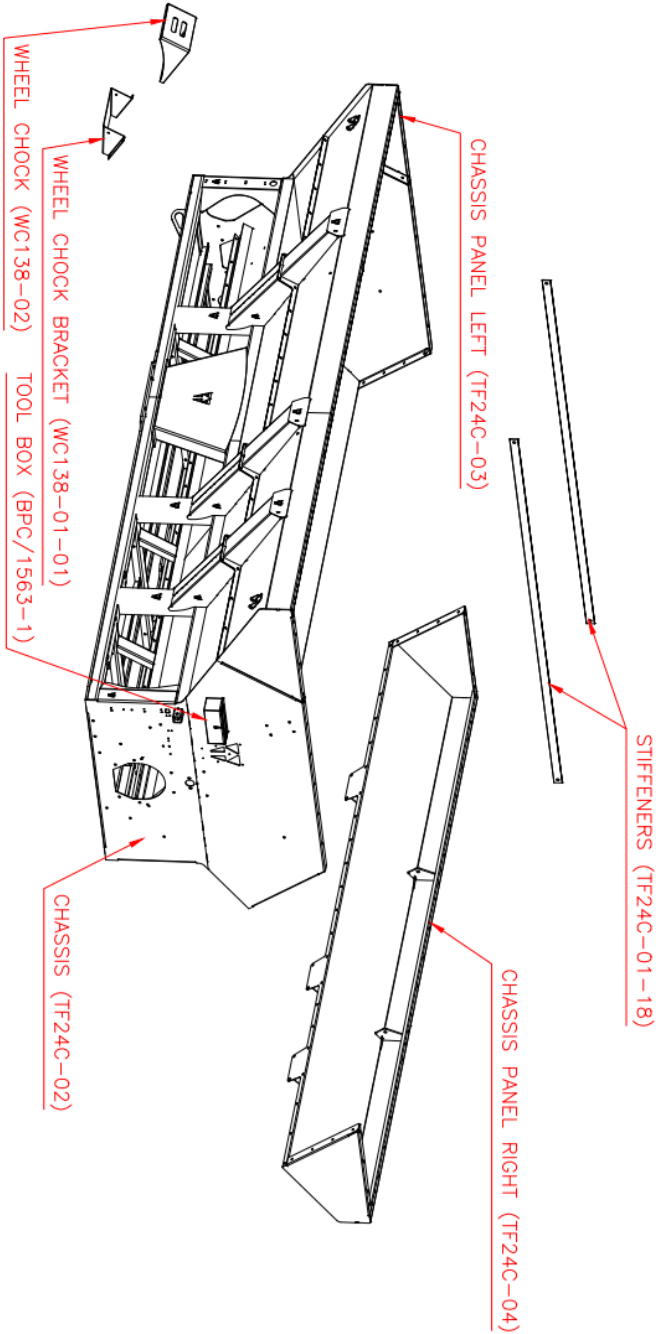

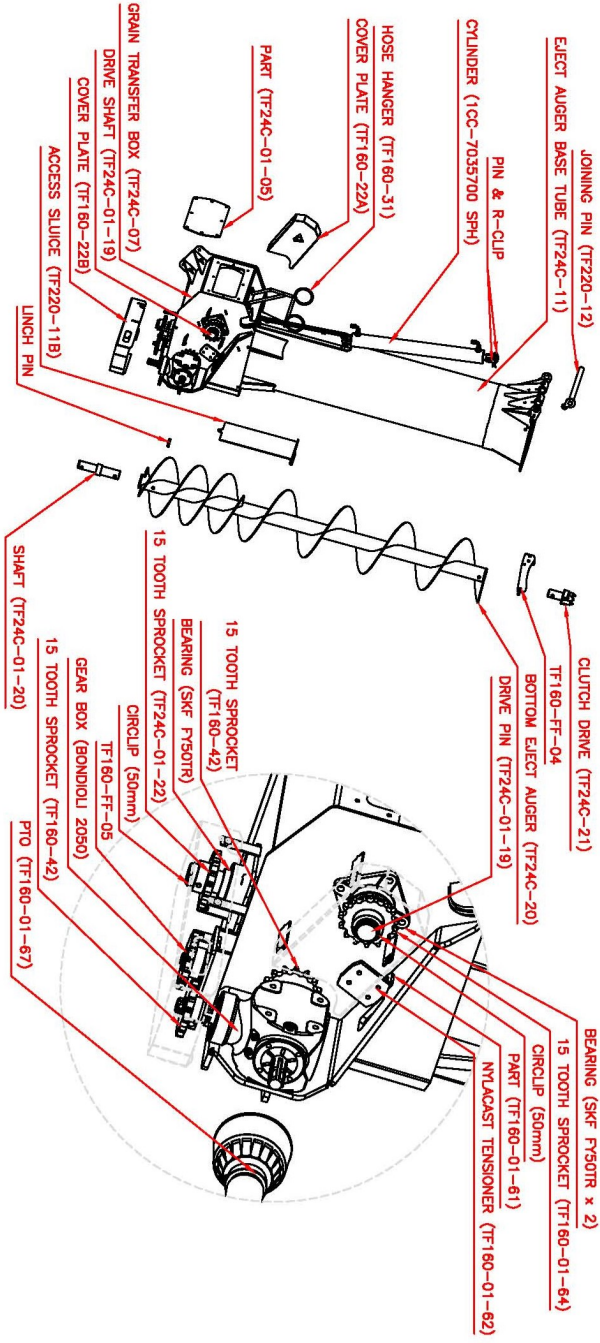

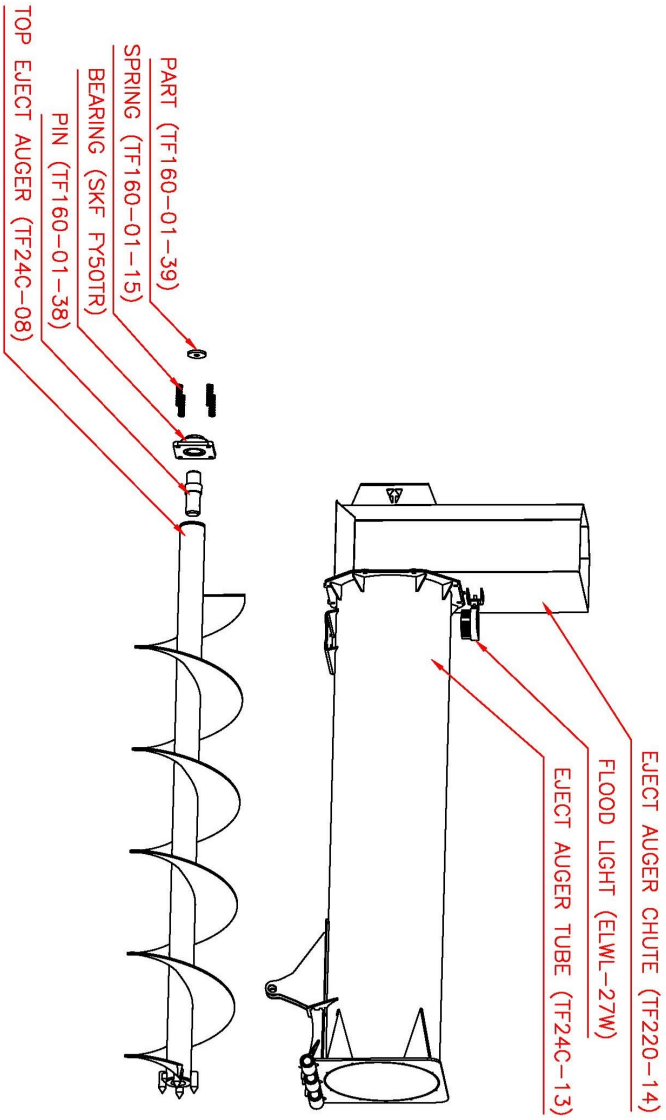

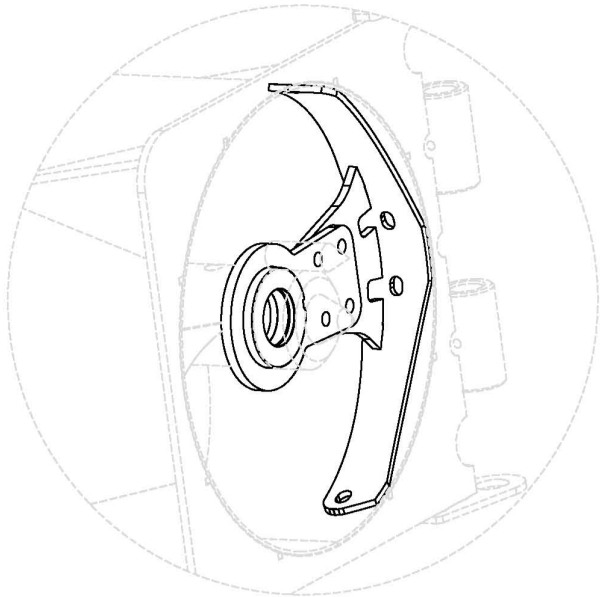
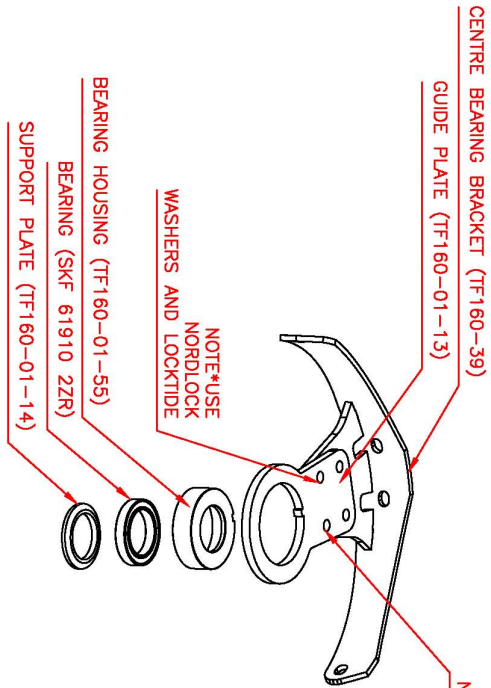

NOTE*USE NORDLOC & LOCKTIDE

TF160-FF-05

Bottom Chain Tensioner Sprocket Assembly.

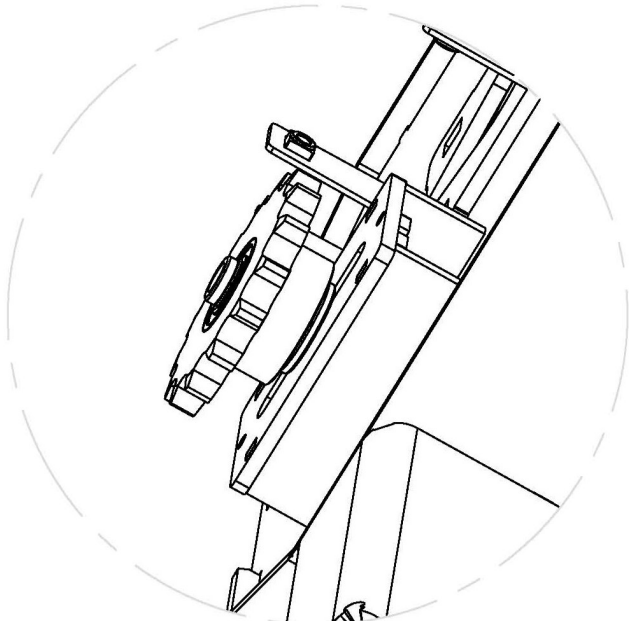
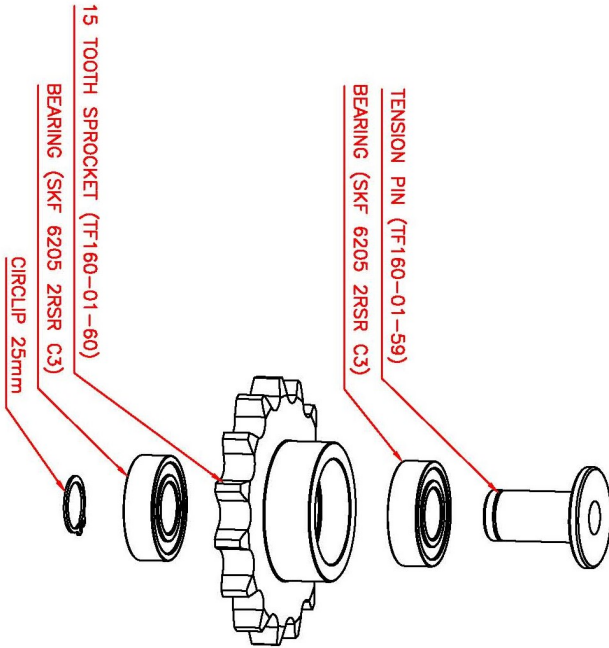

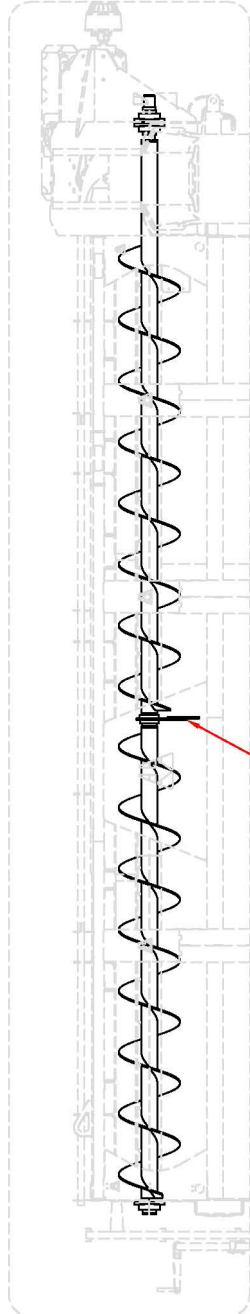
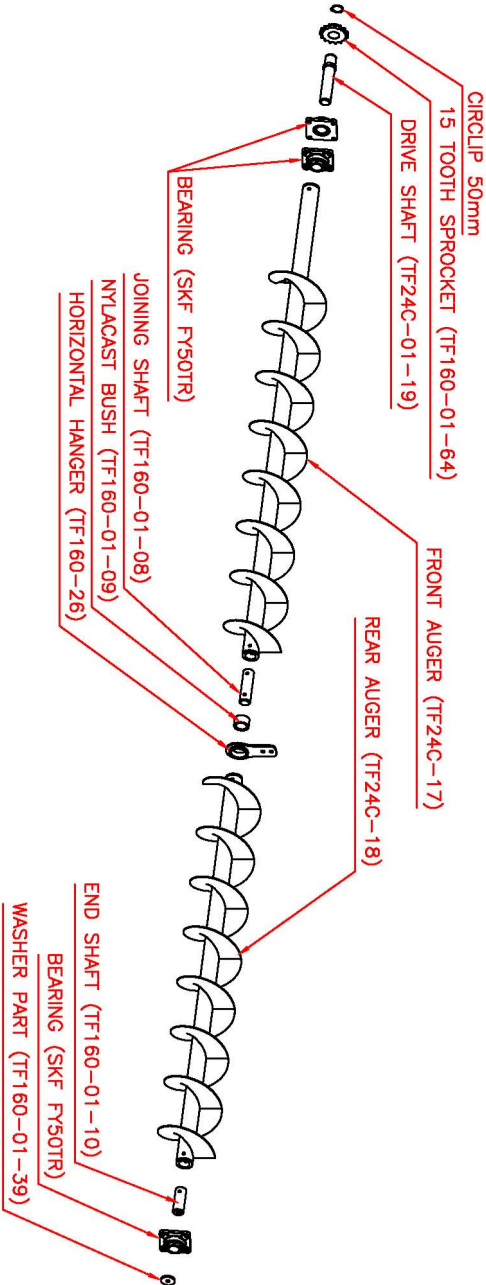

NOTE*MAKE SURE HANGER IS ON THE RIGHT SIDE

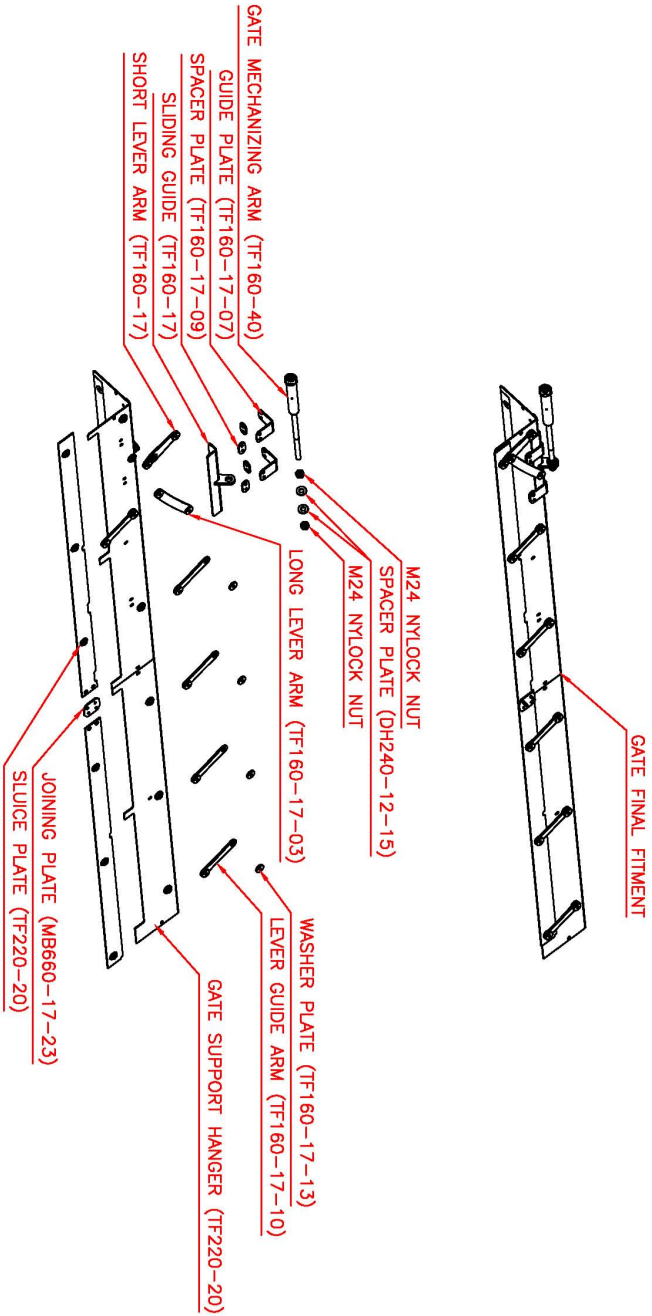

TF24C-FF-08

Bottom Dump Assembly.

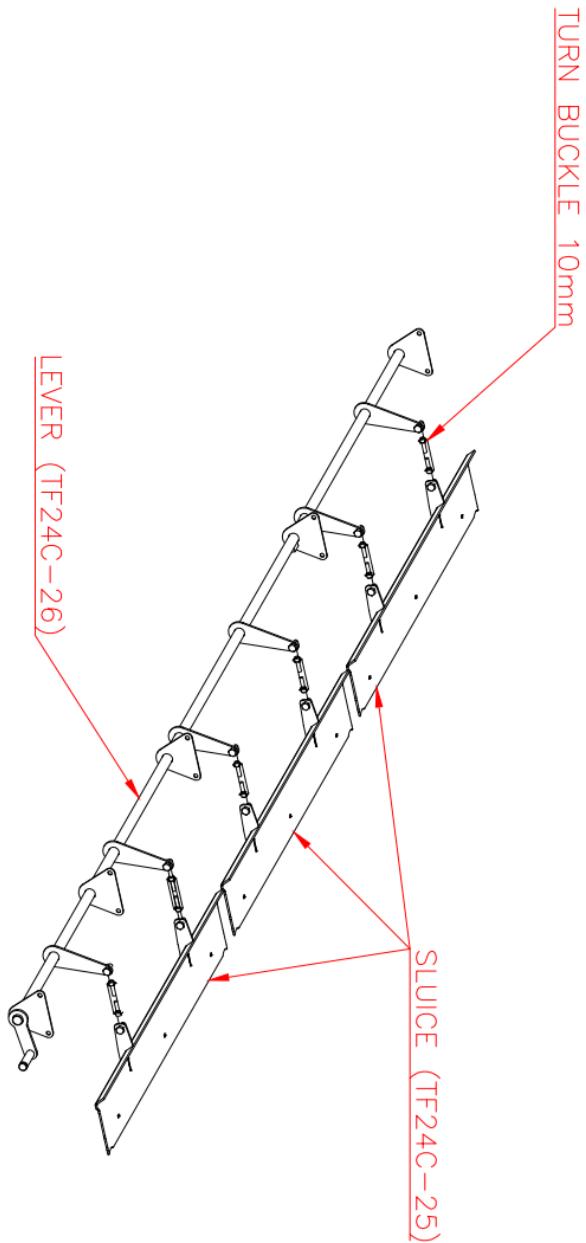

TF24C-FF-09

Belly Plate Assembly.

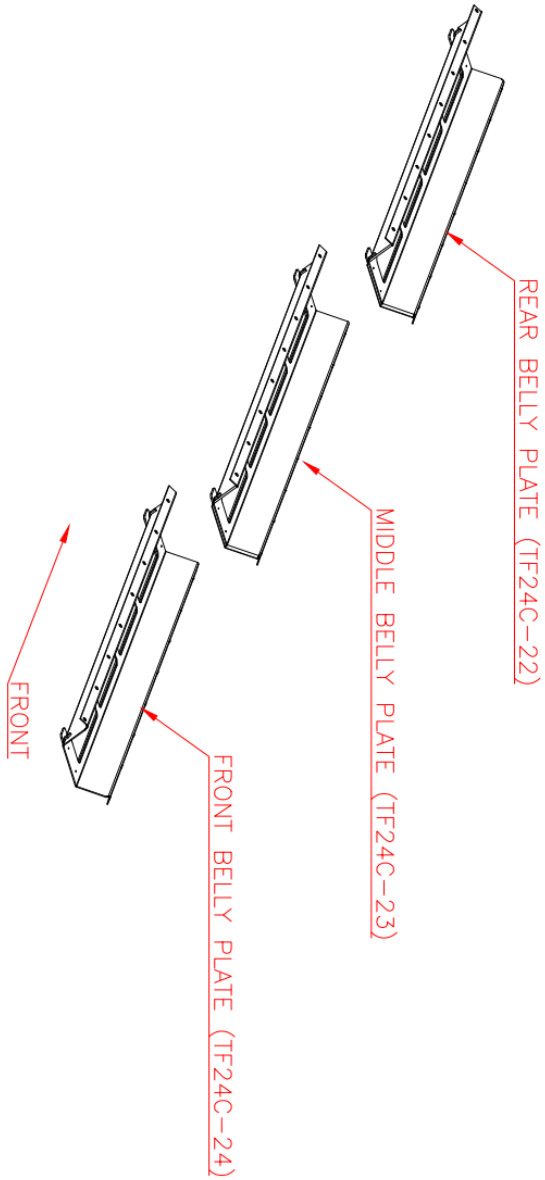

TF24C-FF-10

Top Structure Assembly.

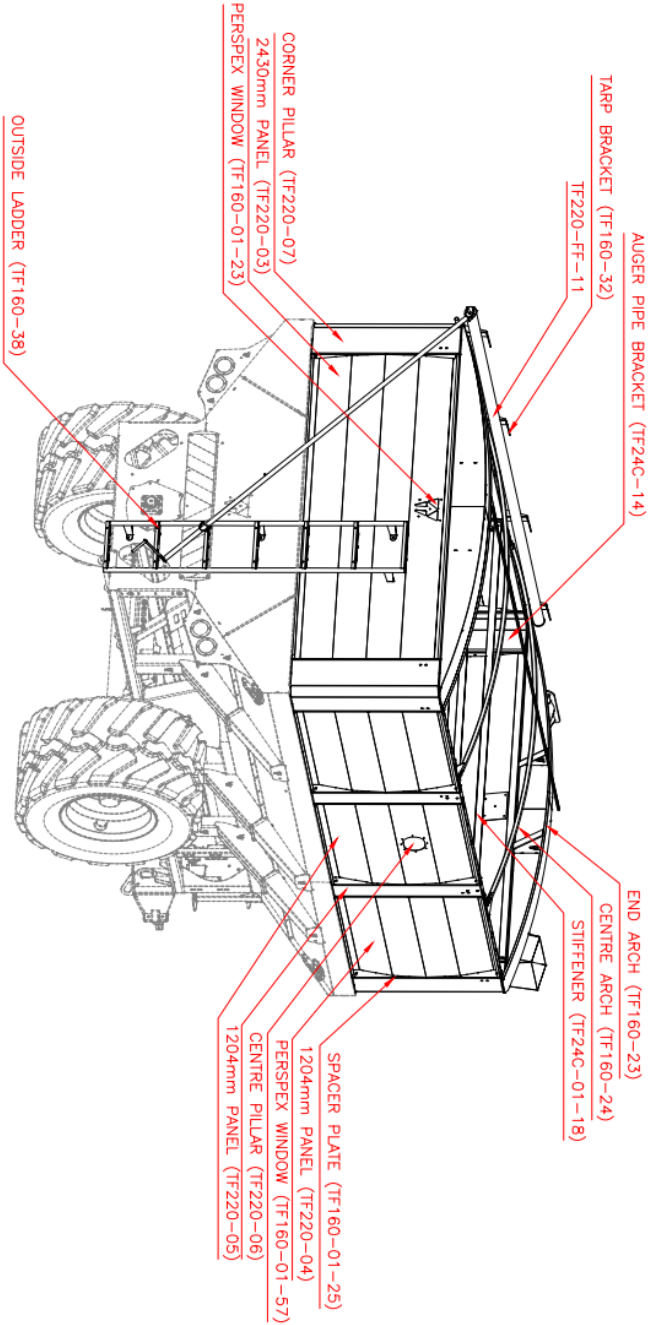

TF220-FF-11

Tarpaulin Assembly.

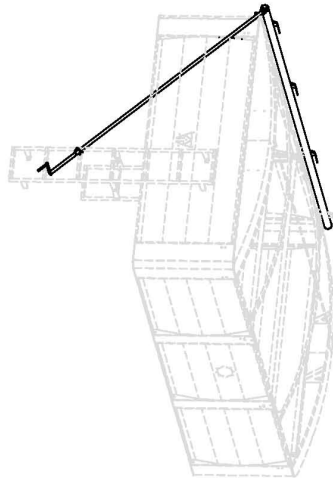
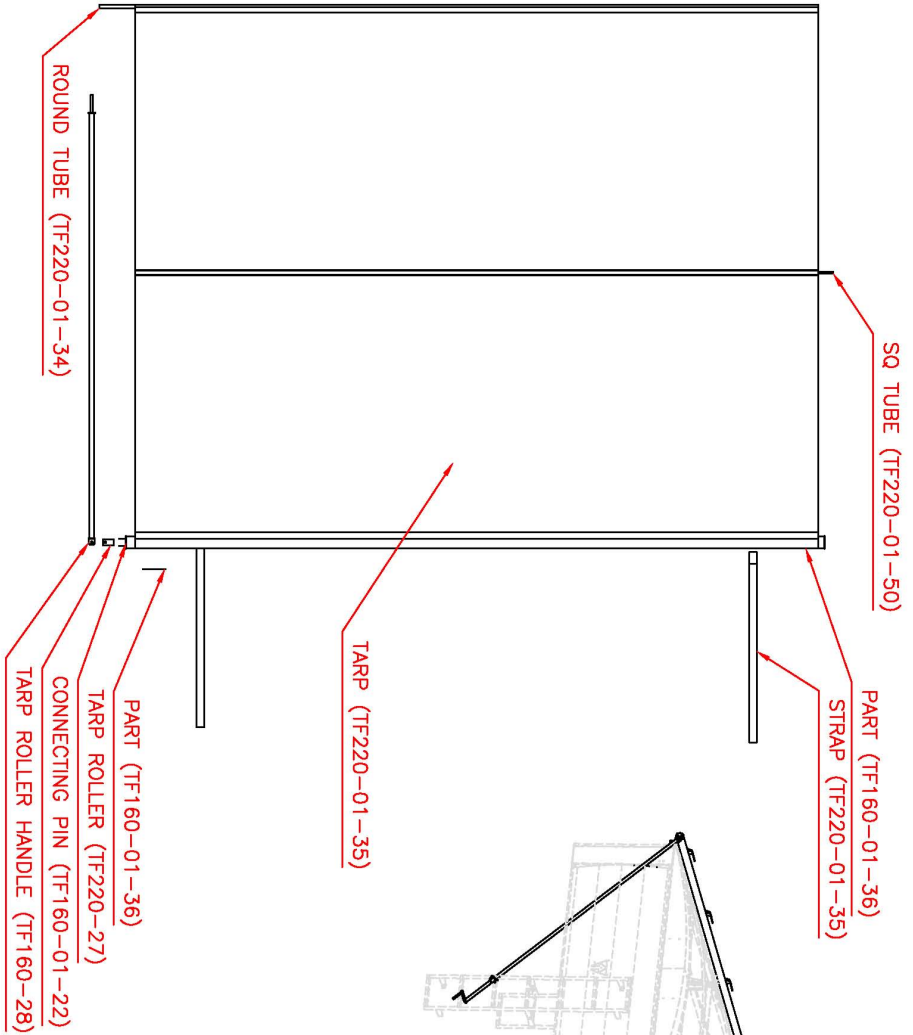

ACL001-FF Light box Assembly.

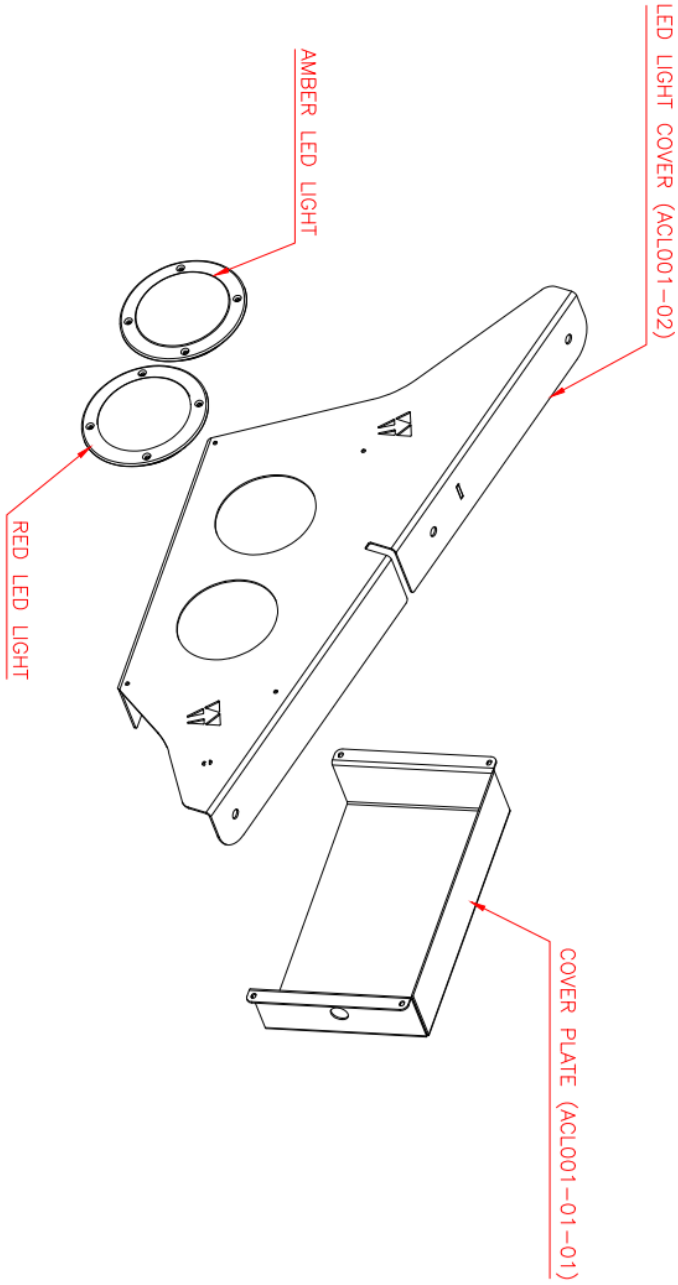

TF220-HD-01 Hydraulic Layout.

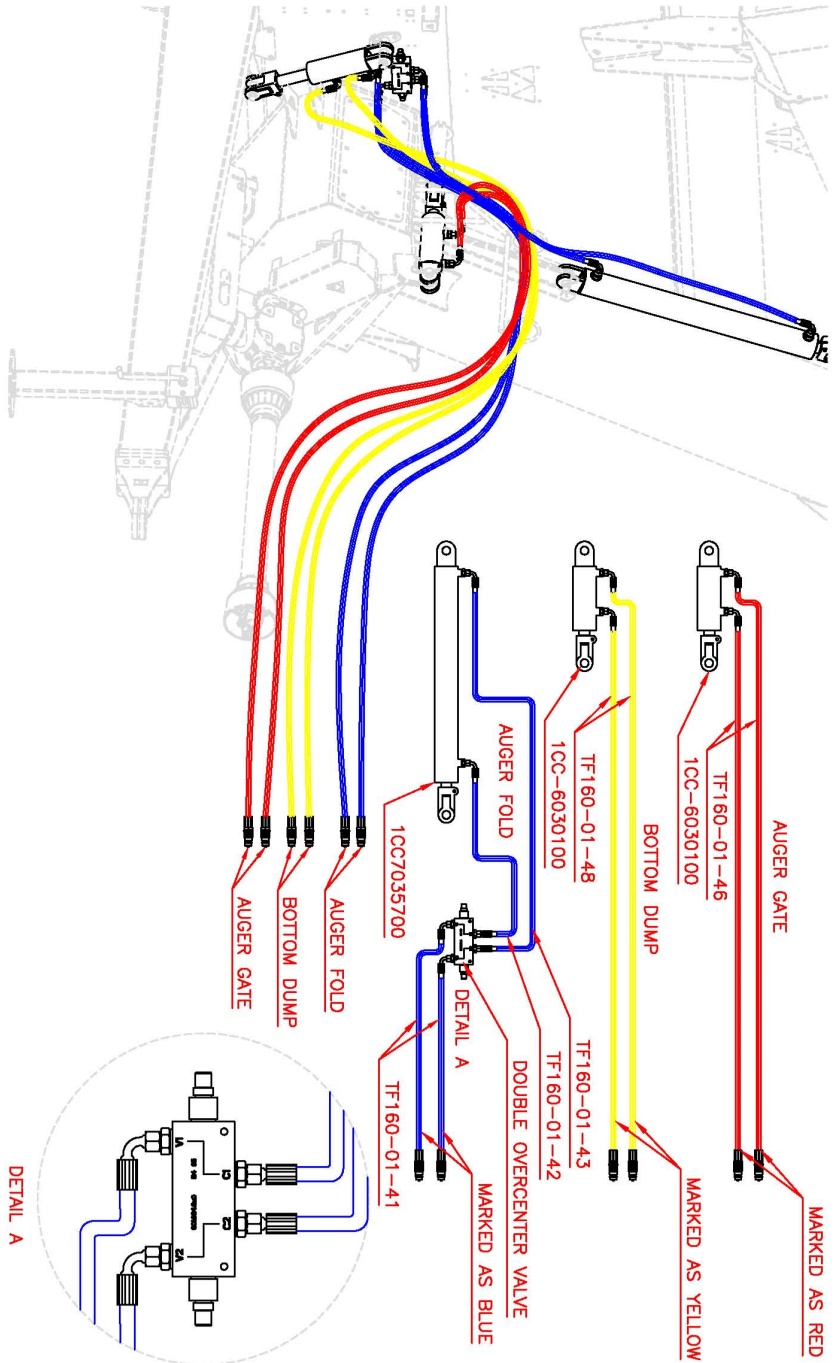

This page was left blank intentionally.



WARRANTY REGISTRATION

Dealer to complete and send to Info@agricad.co.za or fax to 0861001203

Implement:

Serial Number:

Dealer:

Customer Name:

Date of Sale:

Signature Client:

Dealer Stamp:

This implement carries a one year warranty on parts and workmanship under normal and intended use. This warranty is limited to the repair and/or replacement of defective parts.

No wear parts are covered under warranty.

This page was left blank intentionally.

Manufactured in South Africa

for African conditions by

AgriCAD Pty (Ltd)

www.agricad.co.za

Tel: 086100204

For any assistance with AgriCAD parts email us at

parts@agricad.co.za



AgriCAD © copyright
all rights reserved