

# AgriCAD DH280



## Owners Manual

## **Introduction**

### **1. Foreword**

Before operating the implement, read and strictly comply with the operating instructions. In doing so, you will avoid accidents, reduce repair costs and downtime and increase the reliability and service life of your machine. Pay attention to the safety instructions! AgriCAD will not be liable for any damage or malfunctions resulting from failure to comply with the operating instructions.

These operating instructions will assist you in getting to know your implement and in using it correctly for its intended purposes. The operating instructions must be read and strictly adhered to by all persons working on or with the implement.

e.g. Operation (including preparation, fault rectification during work and servicing)

Maintenance (maintenance and inspection)

Transport

We reserve the right to alter illustrations as well as technical data and weights contained in these operating instructions for the purpose of improving the implement without notice.

### **2. Warranty claims**

This implement carries a one year warranty on parts and workmanship.

Wear parts are not covered by this warranty.

### **3. Intended use**

The implement was built in accordance with latest technical standards and generally accepted safety regulations. However, risks of injury to the operator or third parties and impairment of the implement or other tangible assets can occur during use.

The implement must only be operated for its intended use if in a technically good condition, whilst being aware of safety and risks and in strict compliance with the operating instructions!

Faults, particularly those which impair safety, must be remedied immediately. The implement must only be operated, serviced and repaired by persons who are familiar with it and have been made aware of the dangers involved.

Genuine spare parts and accessories from AgriCAD are available for this implement. Spare parts and accessories which are not supplied by AgriCAD, have not been tested or approved by AgriCAD.

Installation or use of non-original AgriCAD products may have a detrimental effect on specific design features of the implement and impair the safety of implement operators and the implement itself.

AgriCAD will not assume liability whatsoever for damage resulting from the use of non-original parts and accessories.

The implement was designed as a harrow for an agricultural application. Any other use beyond this limits, e.g. as a means of transport, is deemed improper.

AgriCAD will not assume liability whatsoever for damage resulting from unintended use. The risk will be borne solely by the user.

Intended use also includes the strict compliance with the operating instructions specified by the AgriCAD.

#### **3.1 Consequential damage**

The Implement was manufactured by AgriCAD with great care. Nevertheless, even when used properly, malfunctions or complete failure may be caused by e.g.:

Damage caused by external influences

Incorrect operation of the machine

In appropriate speed and use when in transport between fields.

You should therefore check the correct function of your machine before and during use.

Liability for consequential damages caused by incorrect operation of the implement is excluded.

### **3.2 Authorised operators**

Operators must be at least 16 years of age.

The operator is responsible for third parties in the operating area.

Only those persons who have been authorised and instructed by the owner may operate the implement.

#### ***The owner must:***

Make the operating instructions available to the operator.

Ensure that the operator understood the operating instructions.

The operating instructions are an integral part of the implement.

#### ***Safety and accident prevention***

The following warnings and safety instructions apply to all sections in these operating instructions.

#### ***Example of Safety symbols***



#### ***Example of Operational Symbols***



#### ***Operational safety***

All protective features and safety equipment, such as detachable protective devices, must be correctly in place and reliably functioning before the machine is put into operation.

Check and tighten nuts and bolts at regular intervals.

Check tyre pressure regularly.

In case of malfunctions immediately stop and secure the machine.

#### ***Road traffic safety***

This implement is manufactured as an agricultural implement and must only be used as an implement on the public roads.

Passengers are strictly forbidden to ride on the machine!

#### ***Hitching / unhitching***

There is a risk of injury to persons when hitching/un-hitching the machine to the drawbar of the tractor.

Only park the machine on a firm and level surface.

Take special care when reversing the tractor.

Never stand between the tractor and machine without a good source of safety.

***Service and maintenance***

Ensure that regular inspections are always carried out.

Prior to performing maintenance and servicing work, ensure that the implement is positioned on firm, level ground.

Before cleaning the implement with high pressure cleaning equipment cover all openings, which should stay clear of water, steam or cleaning agents for reasons of safety or operation.

Do not aim the water jet directly at electrical or electronic components.

Re-tighten screwed connections which have been loosened during servicing and maintenance work.

Take extreme caution when washing with steam-jet or high pressure washers implement can be damaged.

***Hydraulic connections***

Do not connect hydraulic lines to the tractor, before both hydraulic systems (Implement and tractor) are de-pressurised.

The hydraulic system is under high pressure. Check all lines, hoses and screwed connections regularly for leaks and any visible external damage.

After cleaning, check all hydraulic lines for leaks and loose connections.

Check hoses for chafing and signs of other damage.

The hydraulic connections between the tractor and implement are colour-coded in order to exclude operating errors.

***In operation***

Check the area around the implement for unauthorised persons before setting off and starting operation of the implement.

Stay clear of the operating range of hydraulically operated parts.

Use access steps and treads only at standstill.

Passengers are not allowed to ride on the machine during operation!

## Technical data

### Dimensions and weights

Transporting Width: .....3.70 m  
Working Width: .....3.40 m  
Transport Height: .....1.40 m  
Length: .....6.65 m

### Standard design

Tyres: .....400/60R15.5  
Tyre pressure:..... 4 Bar

### Minimum tractor specification

Minimum tractor power required: .....110+ kW  
Minimum hydraulic flow rate: .....20 l/min  
Hydraulic ports: .....1 Double acting.  
1 x double acting: .....Lifting of the chassis.

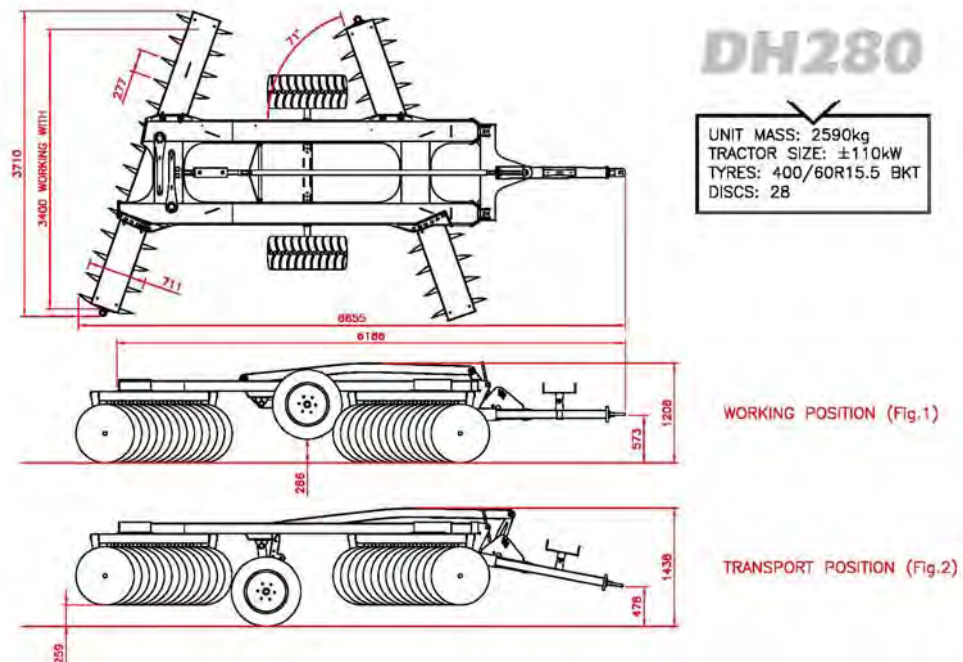

## Setup instruction

### Capacity of tyres

Check the air pressure regularly, preferably every day.  
Under inflating of the tyres may cause damage to the tyres and rims.  
When transporting the implement only travel at speeds below 40km/h.

**Attention!**  
**Refer to Safety and accident prevention**

### Setting up the DH280 to a level position

Hitch the implement to the tractor.  
Wind up the landing leg and store it in the landing leg bracket.  
Connect quick coupling hydraulic hoses to tractor.  
Make sure the implement is lifted to its maximum height when transported.  
Adjust the implement so that the frame is parallel to the ground when the implement is lifted.  
(See transport position)(Fig.2).  
This adjustment is done by adjusting the clevis arm (see DETAIL A picture below, large adjustment) and/or by the balance arm, on the front of the implement's draw bar (see DETAIL B picture below, small adjustments).

### Setting up the DH280 hanger angle

Start off by using the hanger in the middle position.  
The implement was designed to cultivate at a speed of  $\pm 6-10$ km/h depending on the soil type.  
When the implement is in working position (see working position)(Fig.1) the draw bar must be parallel to the ground.  
While the implement is in the working position, one should **NEVER TURN RIGHT**, as this will damage the implement.

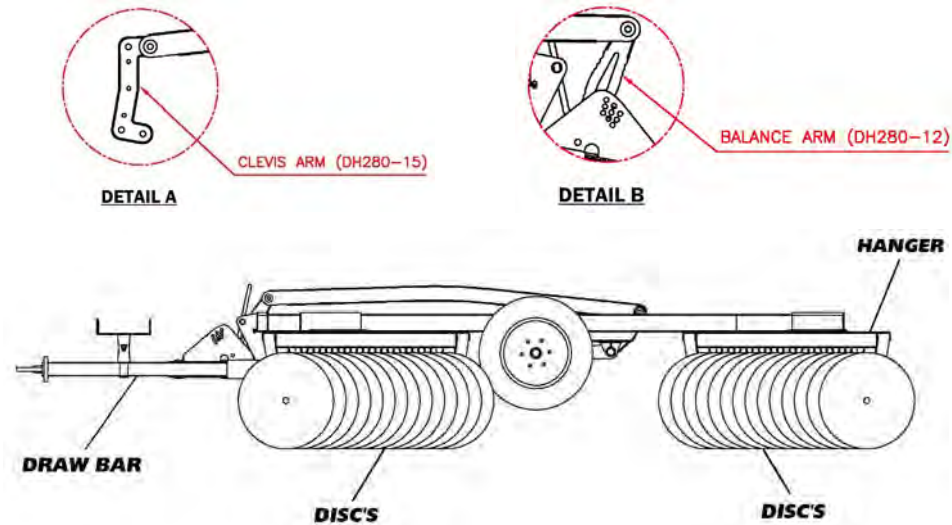

Fig.1

## **Operating instructions**

### **If the implement is skewed.**

#### **To the right**

1. Adjust rear hanger less aggressive or closed.
2. If the implement is still skewed, adjust the front hanger more aggressive or open.

#### **To the left.**

1. Adjust front hanger less aggressive or closed.
2. If the implement is still skewed, adjust the rear hanger more aggressive or open.

### **If the tractor is skewed.**

1. Release the tractor's tow bar so that it can move to the left and right.
2. Drive forwards and look at the direction of the draw bar.
3. Now adjust the implement draw bar laterally in the direction the tractor tow bar moves, until the tow bar no longer moves to one side.

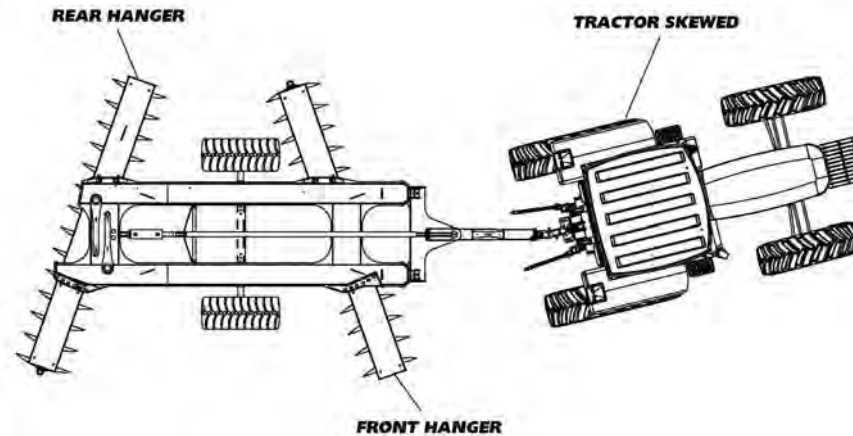
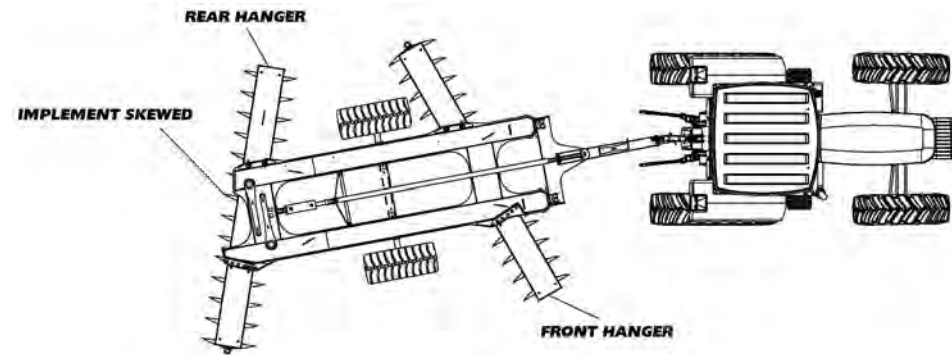

***Coupling of hydraulic system.***

***Attention!***  
***Refer to Safety and accident prevention***

***Attention!***  
***No persons should be in the operating range of the implement***

Connecting hydraulic hoses to the tractor.

1 x double acting: ..... Lifting of the chassis



## Transporting Position (Fig.2).

**Attention!**  
*Refer to Safety and accident prevention*

### STOP AND THINK SAFTY.

Passengers are strictly forbidden to ride on the machine!

Transporting position is very important because if the implement is **NOT** lifted high enough, damage can occur to the disc's or the implement.

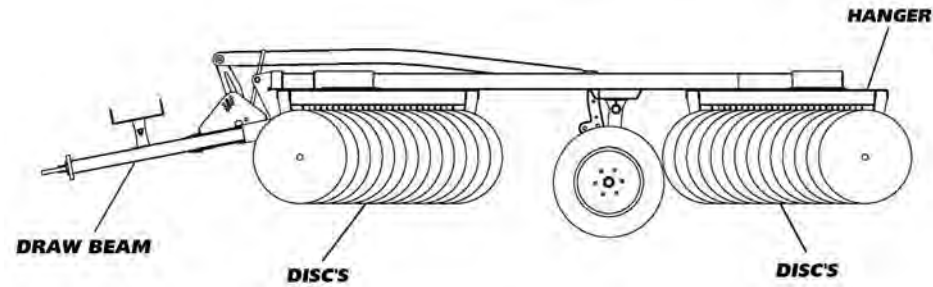

**Attention!**  
*No persons should be in the operating range of the implement*

## Working Position (Fig.1).

### TOP AND THINK SAFTY.

Passengers are strictly forbidden to ride on the machine!

The DH280 is used to destroy reserves after harvesting.

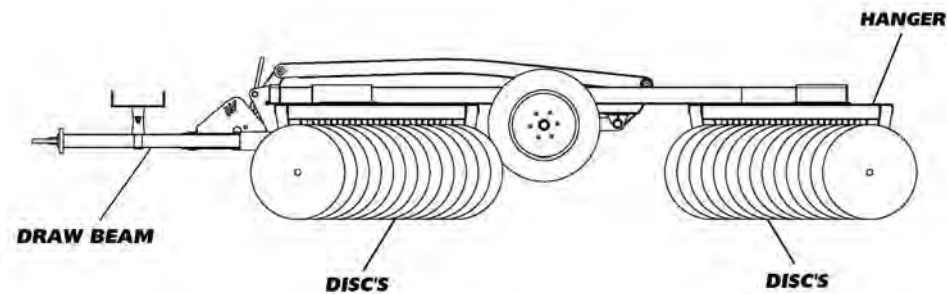

## Lubricating the implement

The implement should be lubricated regularly and after every pressure wash. This ensures operational reliability and reduces the costs of repair work and down times.

Grease bearings as necessary.  
Do not over grease bearings.

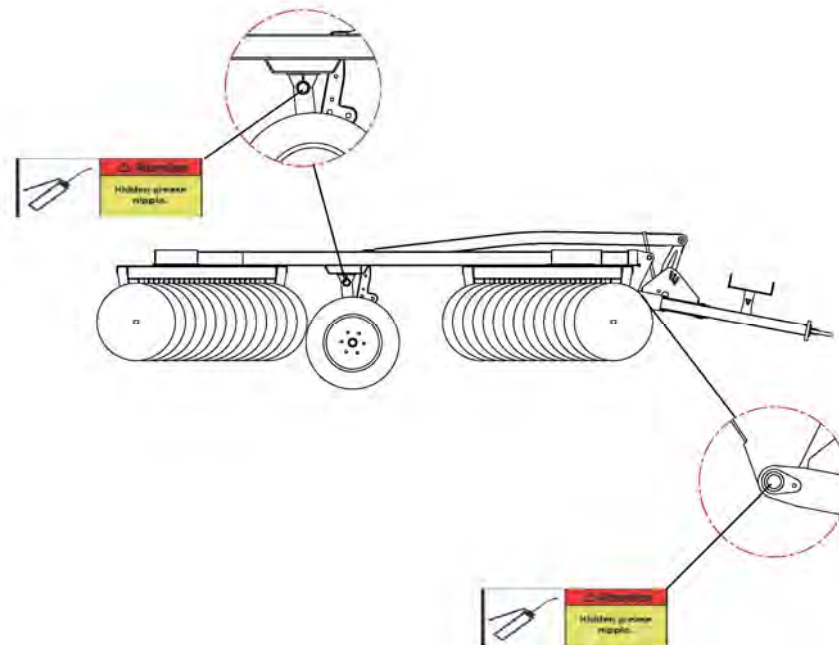
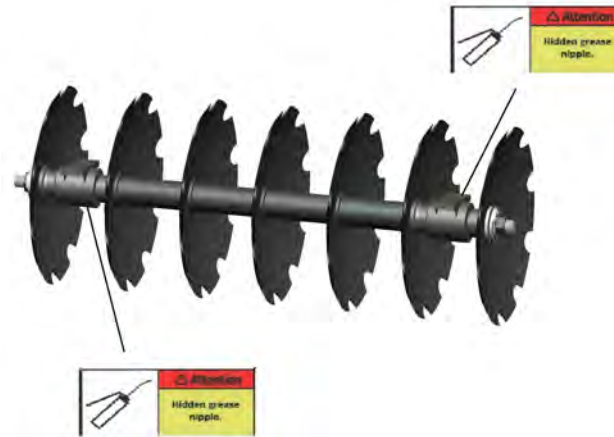

## ***Service & Storing.***

### ***Storing & parking the implement***

The implement should be parked under a roof.  
Park the implement on level and solid ground.  
Use landing leg to store implement.  
Disconnect hydraulic connector and hook into provided storage holders.  
Take care to protect the implement against pest animals like rodents, mice and rats.

### ***Cleaning***

The recommended cleaning and maintenance work should be carried out at regular intervals in order to maintain operation reliability and guarantee optimum performance.  
The hydraulic cylinders, bearings and stickers should not be cleaned with a high pressure cleaner or direct water jet. The seals and bearings are not waterproof under high pressure.

## ***Serial Number Label.***

The implement serial number is indicated on the plate( see the example at the bottom).

This information is useful when inquiring implement spare parts.



DH280-FF-01 - Main Assembly

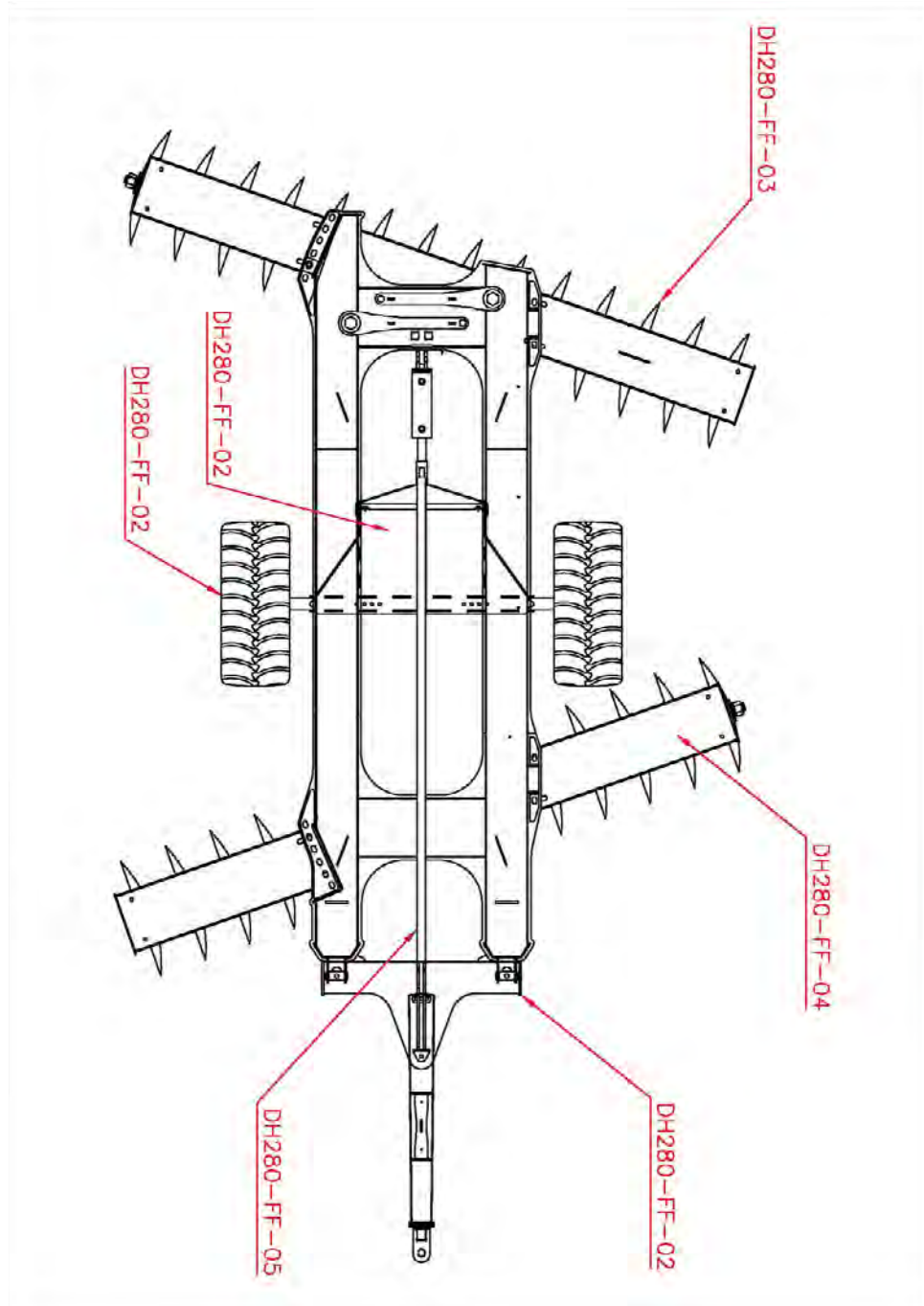

# DH280-FF-02 - Chassis & Axle Assembly

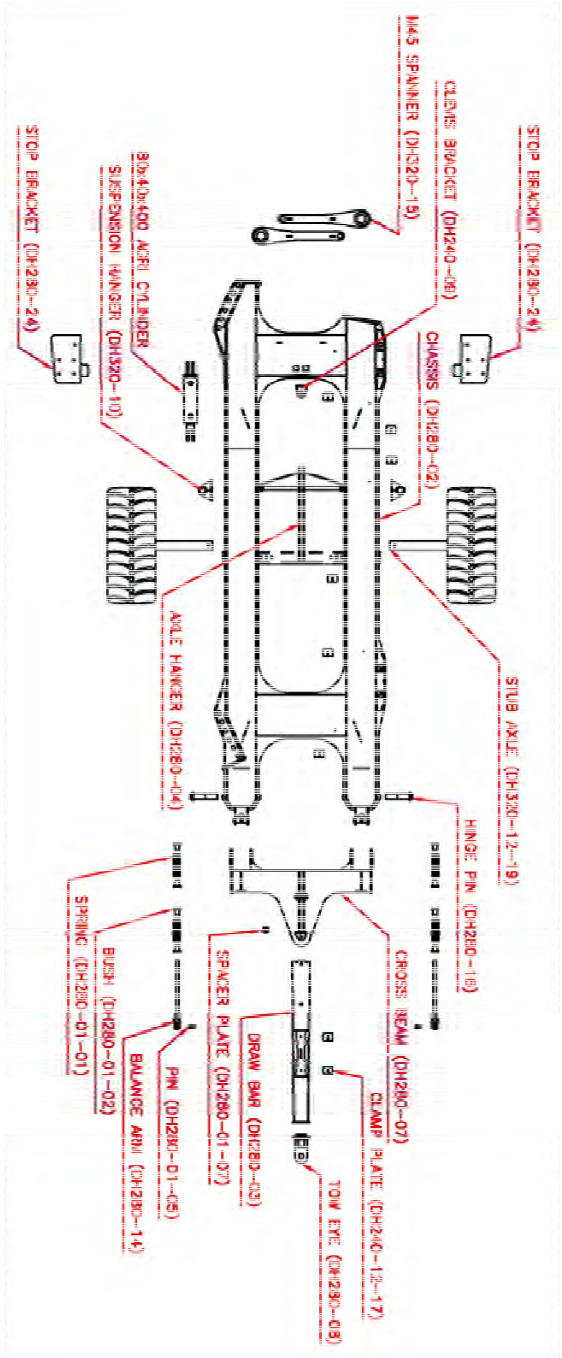

# DH280-FF-03 - Axle Gang Assembly

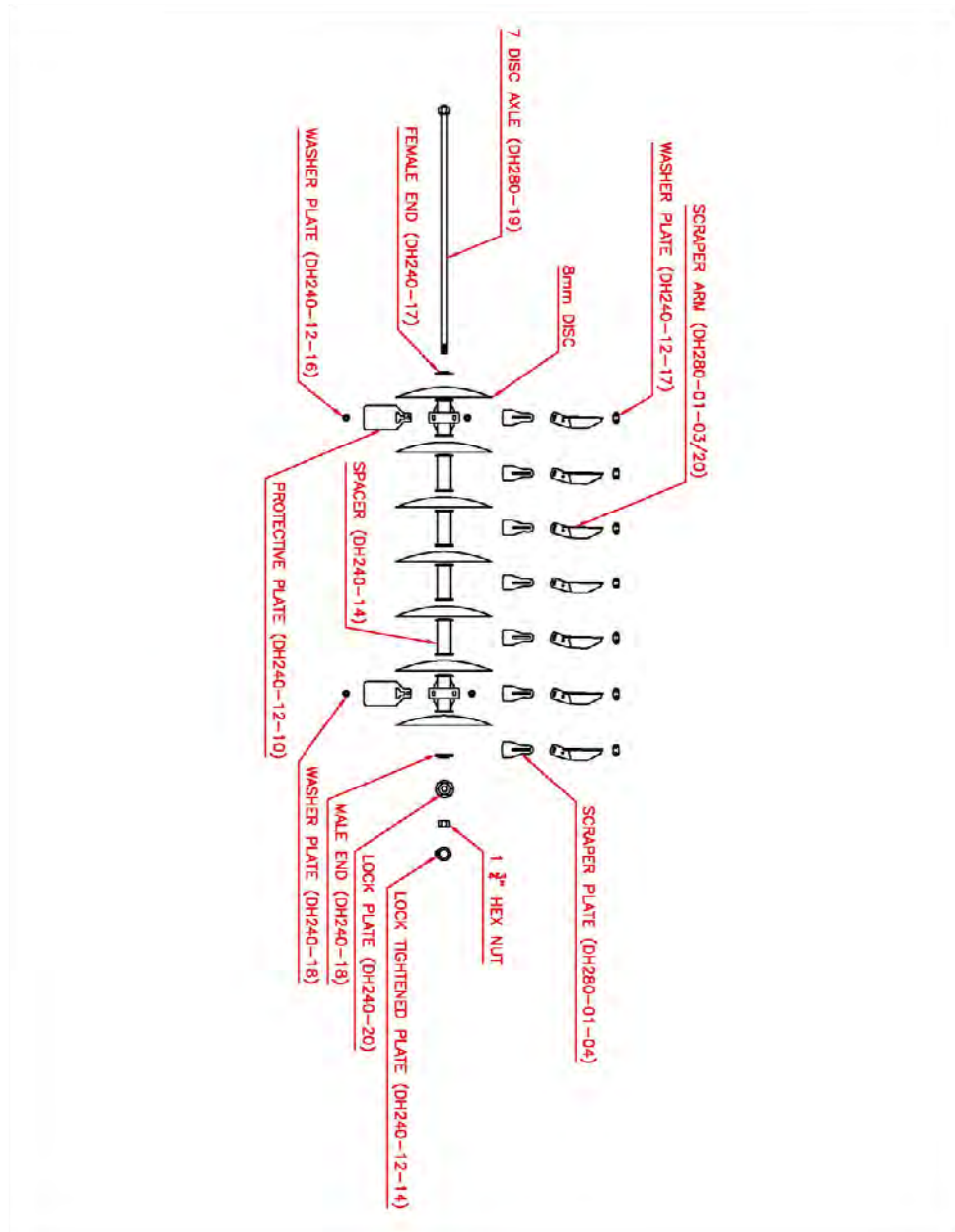

# DH280-FF-04 - Axle Hanger Assembly

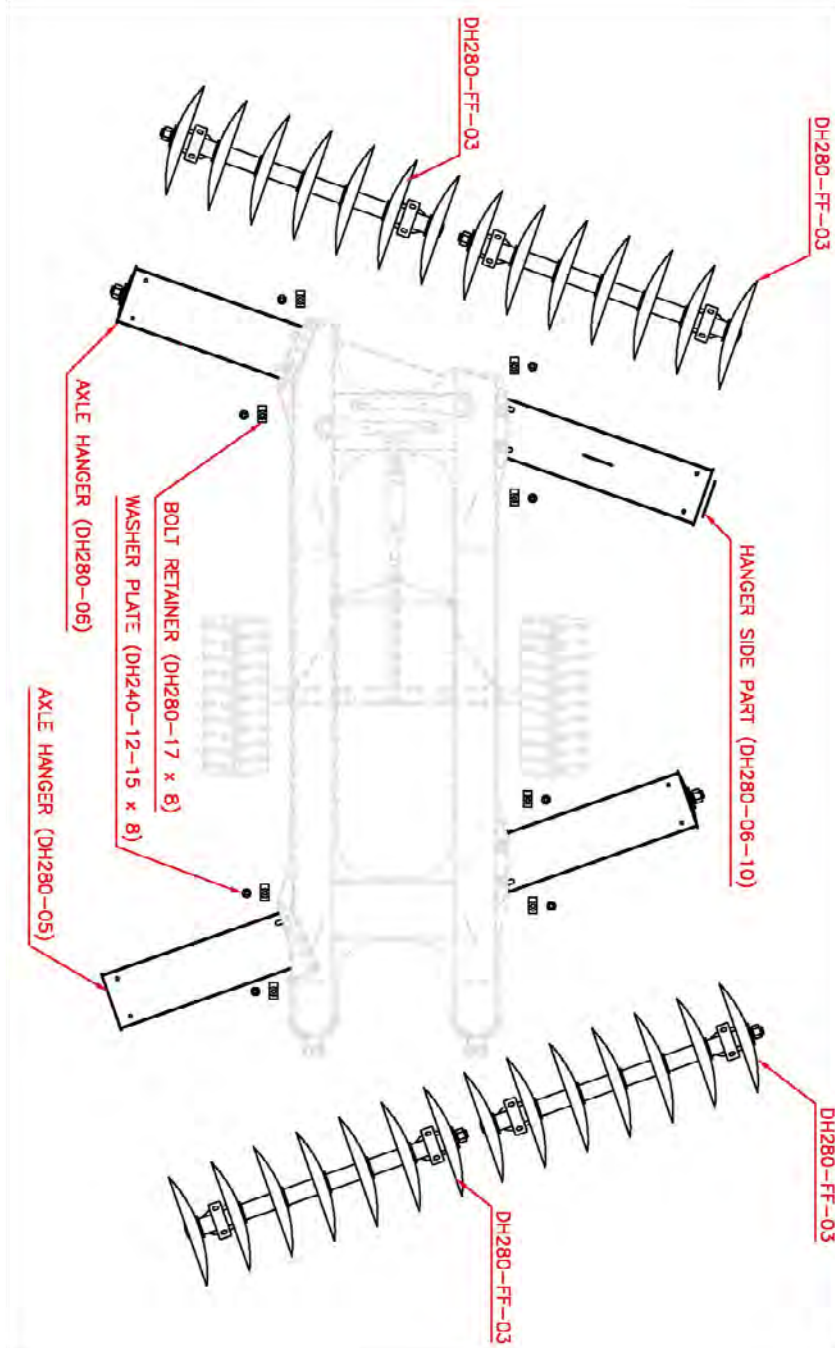

# DH280-FF-05 - Lift Beam Assembly

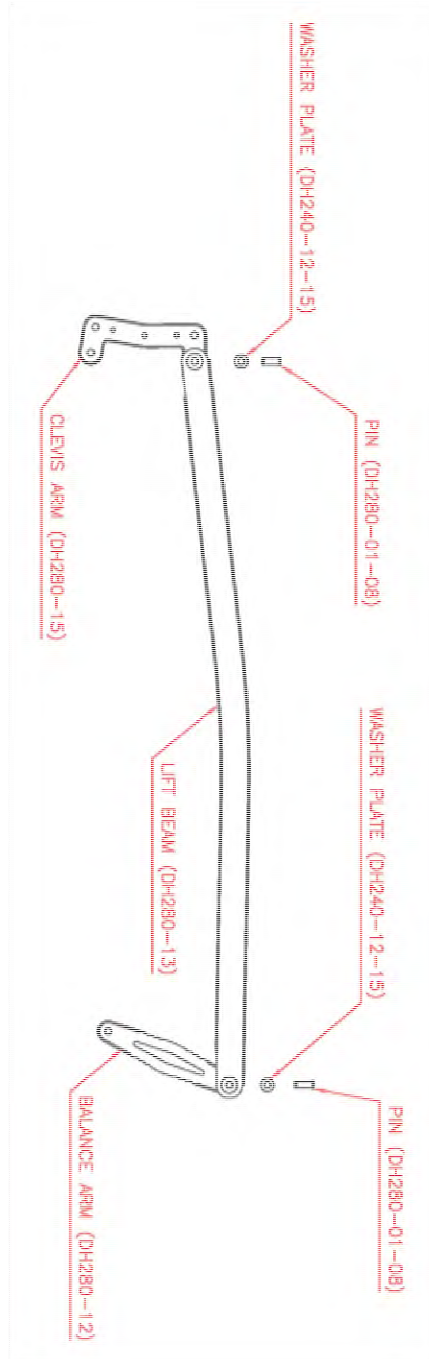



DH280-HD-01 - Hydraulic Assembly

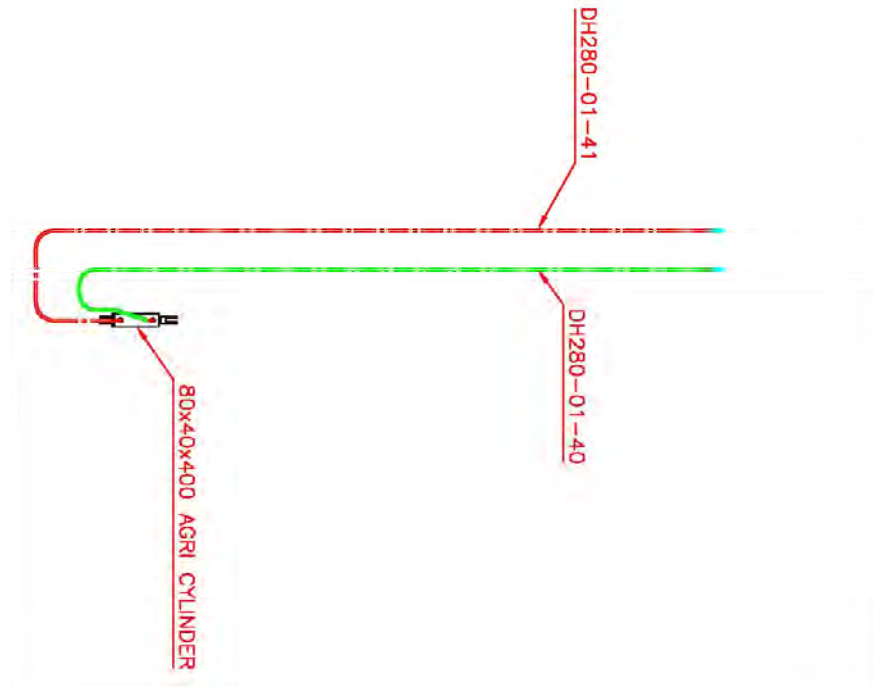
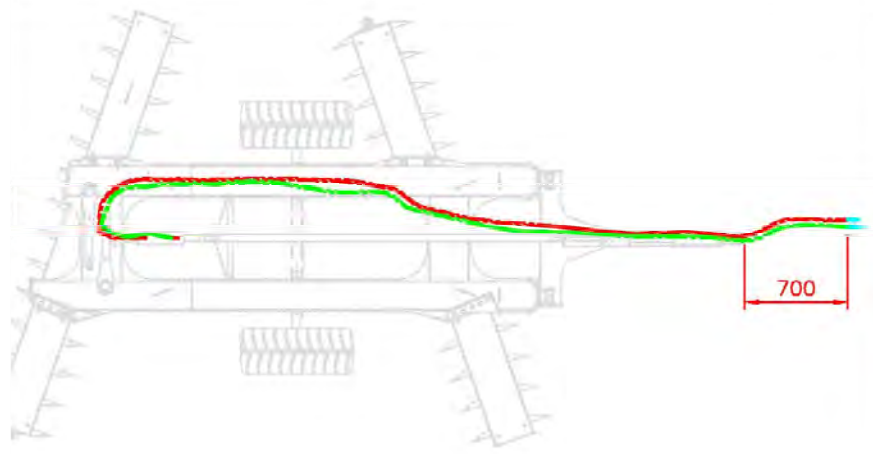

This page was left blank intentionally.



## WARRANTY REGISTRATION

Dealer to complete and send to [Info@agricad.co.za](mailto:Info@agricad.co.za) or fax to 0861001203

Implement: .....

Serial Number: .....

Dealer: .....

Customer Name: .....

Date of Sale: .....

Signature Client: .....

Dealer Stamp:

This implement carries a one year warranty on parts and workmanship under normal and intended use. This warranty is limited to the repair and/or replacement of defective parts.

No wear parts are covered under warranty.

This page was left blank intentionally.

Manufactured in South Africa

for African conditions by

AgriCAD Pty (Ltd)

[www.agricad.co.za](http://www.agricad.co.za)



AgriCAD copyright  
all rights reserved