

AgriCAD BF151

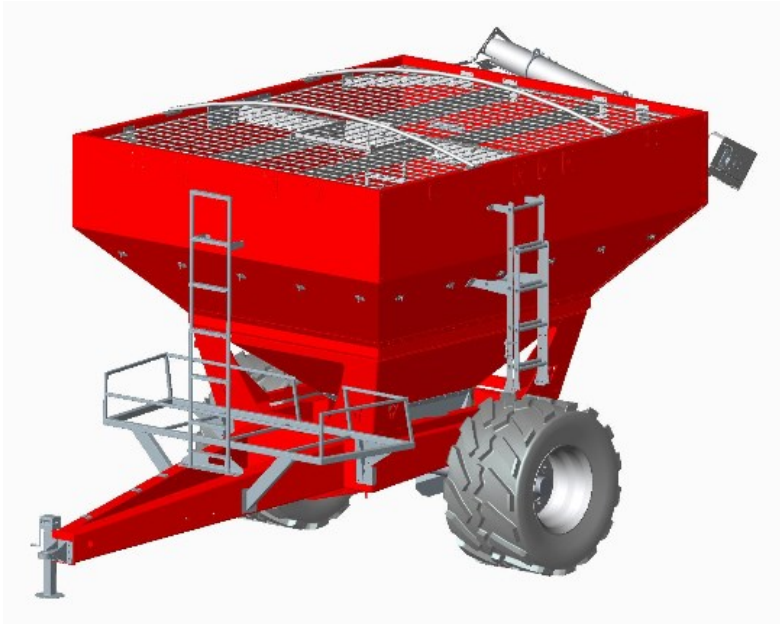

Owners Manual

Introduction

1. Foreword

Before operating the implement, read and strictly comply with the operating instructions. In doing so, you will avoid accidents, reduce repair costs and downtime and increase the reliability and service life of your machine. Pay attention to the safety instructions! AgriCAD will not assume liability for any damage or malfunctions resulting from failure to comply with the operating instructions.

These operating instructions will assist you in getting to know your implement and in using it correctly for its intended purposes. The operating instructions must be read and strictly adhered to by all persons working on or with the implement.

e.g. Operation (including preparation, fault rectification during work and servicing)

Maintenance (maintenance and inspection)

Transport.

We reserve the right to alter illustrations as well as technical data and weights contained in these operating instructions for the purpose of improving the implement without notice.

2. Warranty claims

This implement carries a one year warranty on parts and workmanship.

Wear parts are not covered by this warranty.

3. Intended use

The implement was built in accordance with latest technical standards and generally accepted safety regulations. However, risks of injury to the operator or third parties and impairment of the implement or other tangible assets can occur during use.

The implement must only be operated for its intended use if in a technically good condition, whilst being aware of safety and risks and in strict compliance with the operating instructions!

Faults, particularly those which impair safety, must be remedied immediately. The implement must only be operated, serviced and repaired by persons who are familiar with it and have been made aware of the dangers involved.

Genuine spare parts and accessories from AgriCAD are available for this implement. Spare parts and accessories which are not supplied by AgriCAD, have not been tested or approved by AgriCAD. Installation or use of non-original AgriCAD products may have a detrimental effect on specific design features of the implement and impair the safety of implement operators and the implement itself. AgriCAD will not assume liability whatsoever for damage resulting from the use of non-original parts and accessories.

The implement was designed for the transfer of fertiliser in a agricultural application. Any other use beyond this limits, e.g. as a means of transport, is deemed improper.

AgriCAD will not assume liability whatsoever for damage resulting from unintended use. The risk will be borne solely by the user.

Intended use also includes the strict compliance with the operating instructions specified by the AgriCAD.

3.1 Consequential damage

The Implement was manufactured by AgriCAD with great care. Nevertheless, even when used properly, malfunctions or complete failure may be caused by e.g.:

Blockage or fertiliser bridging (i.e. caused by foreign bodies or moist Fertiliser)

Excessive wear due to the failing of a wear part. (i.e. Damage on auger resulting from bearing failure)

Damage caused by external influences.

Incorrect or inappropriate drive speeds and travel speeds.

Incorrect operation of the machine.

You should therefore check the correct function of your machine before and during each use. Liability for consequential damages caused by operating faults is excluded.

3.2 Authorised operators

Operators must be at least 16 years of age.

The operator is responsible for third parties in the operating area.

Only those persons who have been authorised and instructed by the owner may operate the implement.

The owner must:

Make the operating instructions available to the operator.

Ensure that the operator understood the operating instructions.

The operating instructions are an integral part of the implement.

Safety and accident prevention

The following warnings and safety instructions apply to all sections in these operating instructions.

Example of safety symbols



Example of operational Symbols



Operational safety

The machine registration form has to be completed and returned to AgriCAD.

All protective features and safety equipment, such as detachable protective devices, must be correctly in place and reliably functioning before the machine is put into operation.

Check and tighten nuts and bolts at regular intervals.

Check tyre pressure regularly.

In case of malfunctions immediately stop and secure the machine.

Road traffic safety

This implement is manufactured as an agricultural implement and must only be used as an implement on the public roads.

Passengers are strictly forbidden to ride on the machine!

Hitching / unhitching

There is risk of injury to persons when hitching/un-hitching the machine to the drawbar of the tractor.

Only park the machine on a firm and level surface.

Take special care when reversing the tractor.

Never stand between tractor and machine.

Service and maintenance

Ensure that regular inspections are always carried out.

Prior to performing maintenance and servicing work, ensure that the implement is positioned on firm, level ground.

Before cleaning the implement with high pressure cleaning equipment cover all openings, which should stay clear of water, steam or cleaning agents for reasons of safety or operation.

Do not aim the water jet directly at electrical or electronic components.

Re-tighten screwed connections which have been loosened during servicing and maintenance work.

Take extreme caution when washing with steam-jet or high pressure washers implement can be damaged.

Hydraulic connections

Do not connect hydraulic lines to the tractor, before both hydraulic systems (Implement and tractor) are de-pressurised.

The hydraulic system is under high pressure. Check all lines, hoses and screwed connections regularly for leaks and any visible external damage.

After cleaning, check all hydraulic lines for leaks and loose connections.

Check hoses for chafing and signs of other damage.

The hydraulic connections between the tractor and implement are colour-coded in order to exclude operating errors.

In operation

Check the area around the implement un authorised persons before setting off and starting operation of the implement.

No persons should be in the operating range or when opening or closing augers.

Do not remove any of the mandatory and supplied protective devices.

Stay clear of the operating range of hydraulically operated parts.

Use access steps and treads only at standstill.

Passengers are not allowed to ride on the machine during operation!

Technical data

Dimensions and weights

Width:3.00 m
 Height:.....3.50 m
 Height with auger:.....5.00 m
 Length:6.00 m

Standard design

Payload:.....15000L
 Auger - foldable ø:.....200mm
 Tyres:.....710/50 R26.5
 Tyre pressure:.....4 Bar
 Maximum speed with full load:15km/h

Minimum tractor specification

Minimum tractor power required:92+ kW
 Minimum hydraulic flow rate:40 l/min.
 Hydraulic Valve bank:.....1 Acting ports.
 Single acting:Folding of auger.
 Single acting:Auger sluice.
 Single acting:Turn action of Ager.

BF151

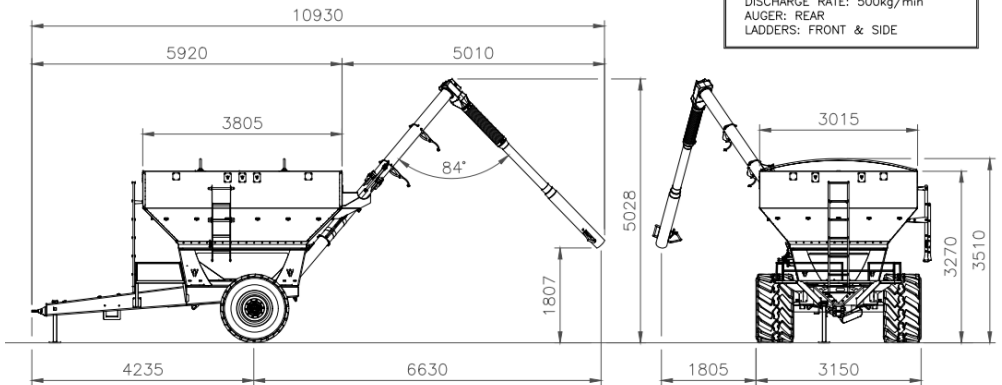

Operating instructions

Load bearing capacity of tyres

When filling to maximum payload (maximum load bearing capacity), the tyres must be inflated to 4.0 bar.
Check the air pressure regularly, preferably every day.
Under inflating of the tyres may cause damage to the tyres and rims.
When operating with maximum payload only travel at speeds below 15km/h.

Hitching the bulk fertiliser bin

Attention!
Refer to Safety and accident prevention

Hitch the fertiliser bin to the tractor.
Wind up the landing leg and store it on the support bracket on the fertiliser bin.
Connect quick coupling hydraulic hoses.

Coupling of hydraulic system.

Attention!
Refer to Safety and accident prevention

Attention!
No persons should be in the operating range of the working auger - open or closed

Connecting hydraulic hoses to the tractor.

1 x Single acting:..... 3 Way valve bank x 1.

Discharging fertiliser from the implement.

Attention!

There is a danger of electric shock when working with an unfolded auger, be aware of any overhead power lines.

Do not open augers while moving.

Do not open or close the augers while the implement's hydraulic motor is engaged!

Move to the unloading point to discharge.

With tractor engine running at a constant rpm of around 1200:

Open the auger up against the end stop.

Open auger sluice on implement to desired position by moving lever on 3 way valve bank.

Holding the telescopic pipe over the planter seed bin opening, start the feeder auger by using the lever on the telescopic pipe.

When the filling of the planter seed bin is finished stop the feeder auger.

The auger gate must be closed while the last planter seed bin is almost filled to prevent fertiliser spillage when the auger is closed for implement movement.

Close the auger for movement or road travel of the implement.

Adjusting discharge rate of fertiliser.

The rate of fertiliser discharge from the eject auger can be adjusted by means of the following:

By adjusting the hydraulic flow rate.

By adjusting the auger sluice opening.

Hydraulic flow rate adjustment

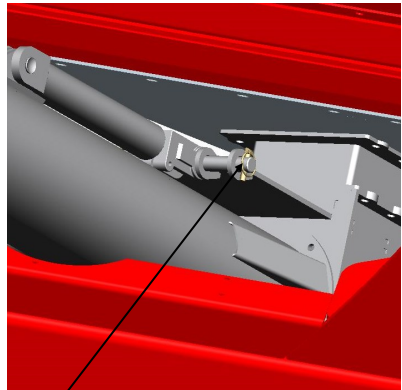
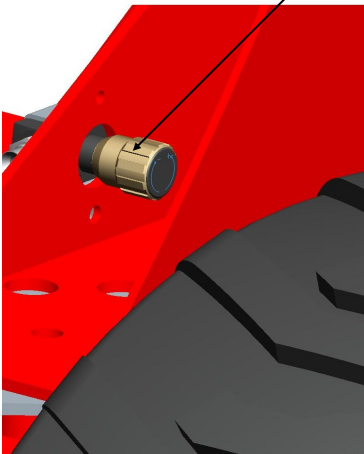

Auger sluice

3 Way valve bank operation

Attention!
*Refer to Safety and accident prevention
No persons under 16 should operate bulk fertiliser bin.*

Hydraulic motor

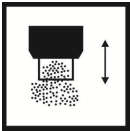

Auger sluice



Auger discharge pipe

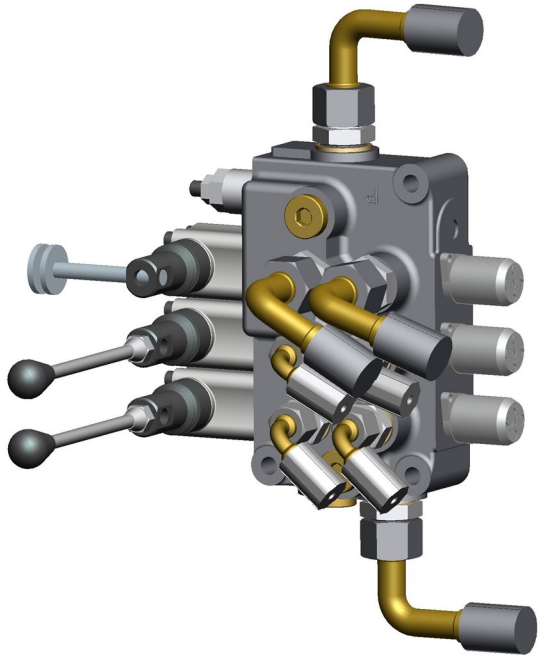

Auger discharge pipe

Attention!
Refer to Safety and accident prevention
No persons under 16 should operate bulk fertiliser bin.

When operating the auger discharge pipe make sure that no one is in the way of the pipe.
See sticker for warning when storing auger discharge pipe on storage bracket.
This is applicable for the front and rear discharge pipe.

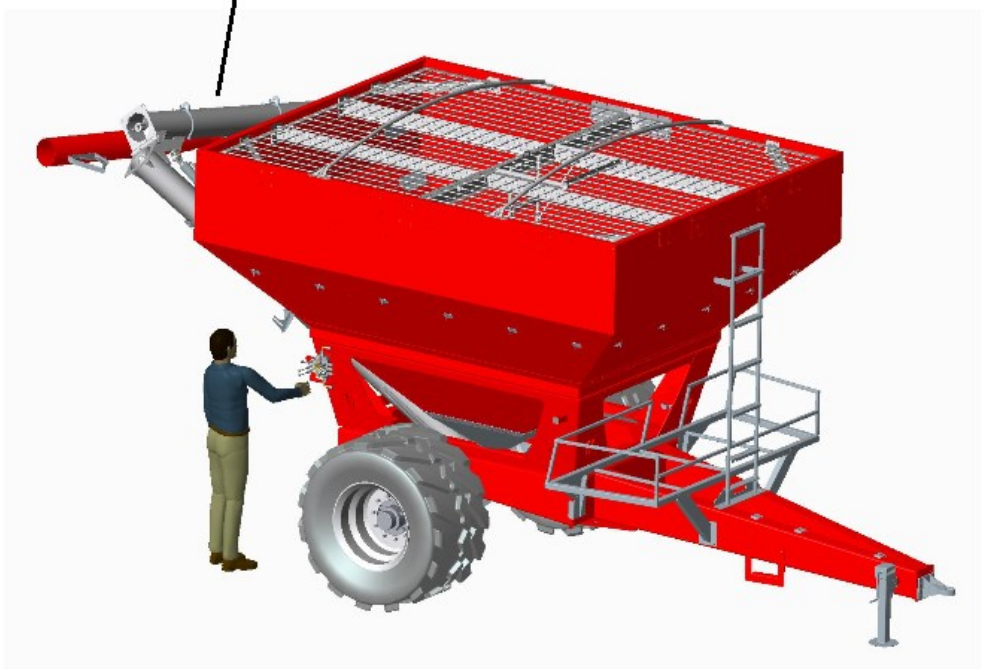
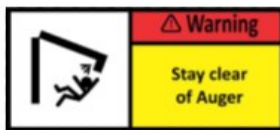

Cleaning the bin using the bottom excess cap

Attention!
Refer to Safety and accident prevention

Switch off the tractor and remove the key from the ignition.
Residues inside the bin can be removed through opening the bottom excess cap.
For this purpose drive the implement to a point of choice and open bottom excess cap.
All or most of the excess residue will fall free from the bin.
Close access cap once all excess fertiliser was removed.
Make sure auger sluice is close when entering the implement.

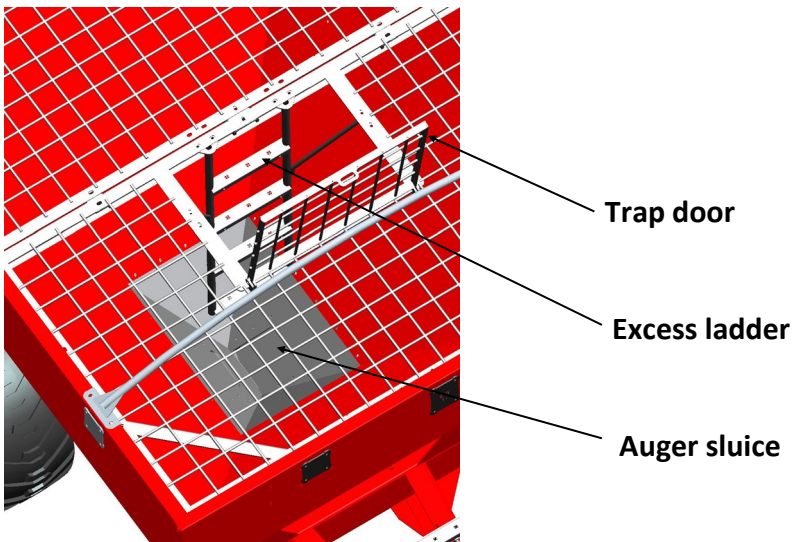
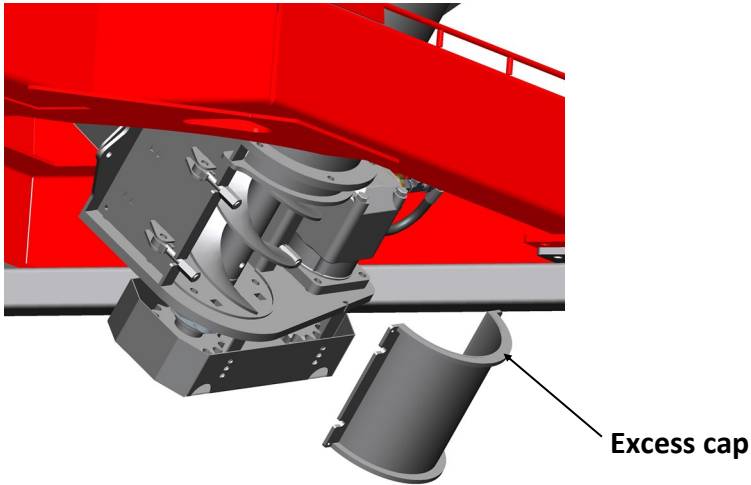

Tarpaulin

*The implement is equipped with a tarpaulin to cover the transported fertiliser.
The tarpaulin protects the transported fertiliser against water and other elements.*

The tarpaulin is a box type tarp.

Before installing tarp make sure trap door is closed.

Make sure no one is inside the implement when installing tarp.

To hold tarp in place hook shock cord over the tarp hook bracket.

Trap door

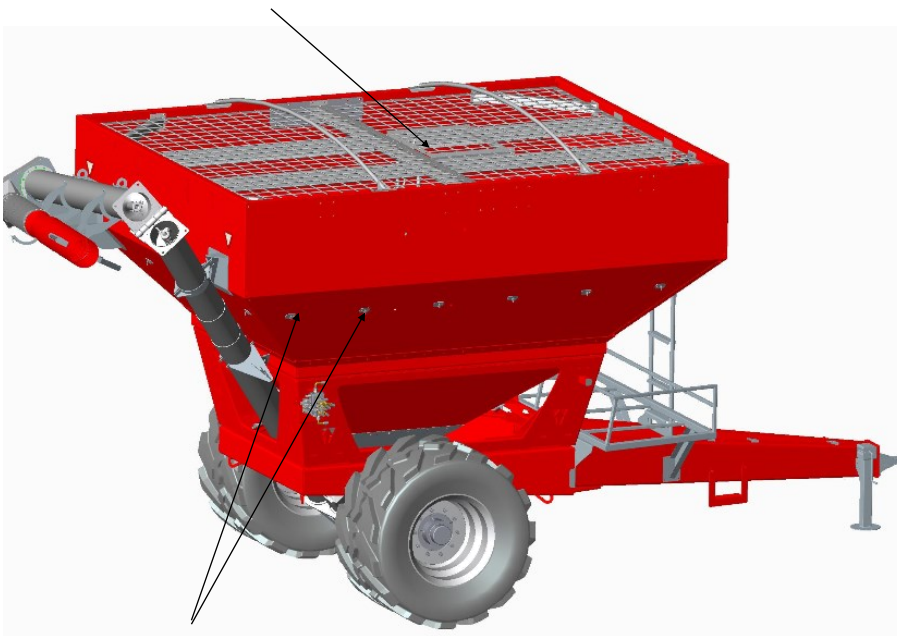

Tarp hook brackets

Service & Storing.

Storing & Parking the implement

The implement should be parked under a roof so that no moisture can accumulate in the fertiliser.

Park the implement on level and solid ground.

When parked for longer periods, it is recommended to open the auger sluice.

Move the landing leg from its storage position on the chaser bin and extend it.

Disconnect hydraulic connections and hook into provided storage holders.

Take care to protect the chaser bin against pest animals like rodents, mice and rats.

Cleaning

The recommended cleaning and maintenance work should be carried out at regular intervals in order to maintain operational reliability and guarantee optimum performance.

The hydraulic cylinders, bearings and stickers should not be cleaned with a high-pressure cleaner or direct water jet. The seals and bearings are not waterproof under high pressure.

Serial Number Label.

The implement serial number is indicated on the plate(see the example at the bottom).

This information is useful when inquiring implement spare parts.

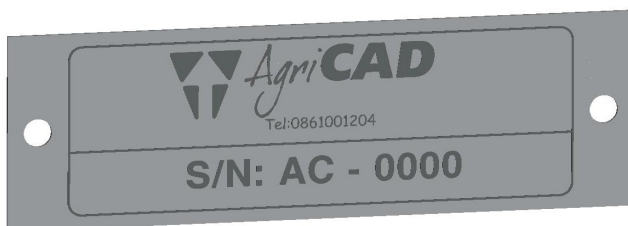

Lubricating the implement

The implement should be lubricated regularly and after every pressure wash. This ensures operational reliability and reduces the costs of repair work and down times.

Lubricate chain regularly.
Grease bearing as necessary.
Do not over grease bearings.

Lubrication points

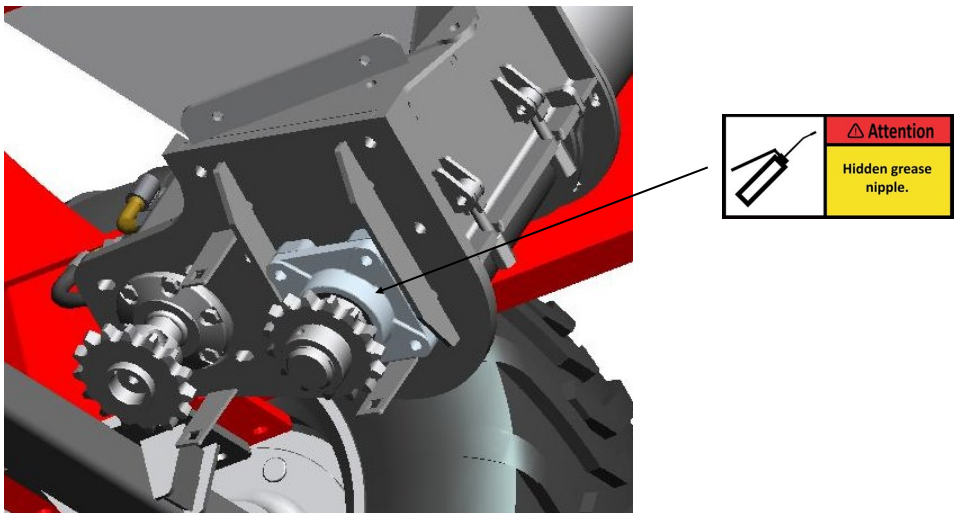
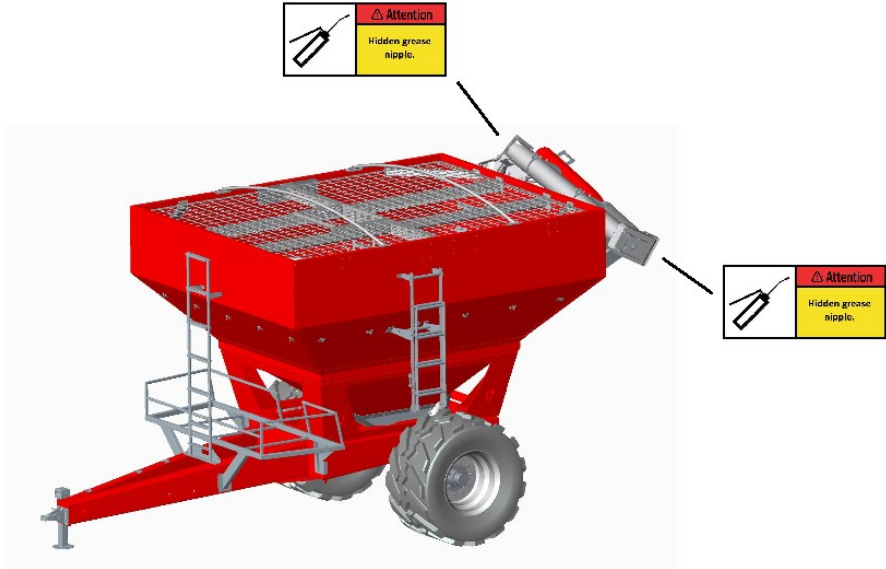

Main Assembly - BF151-FF

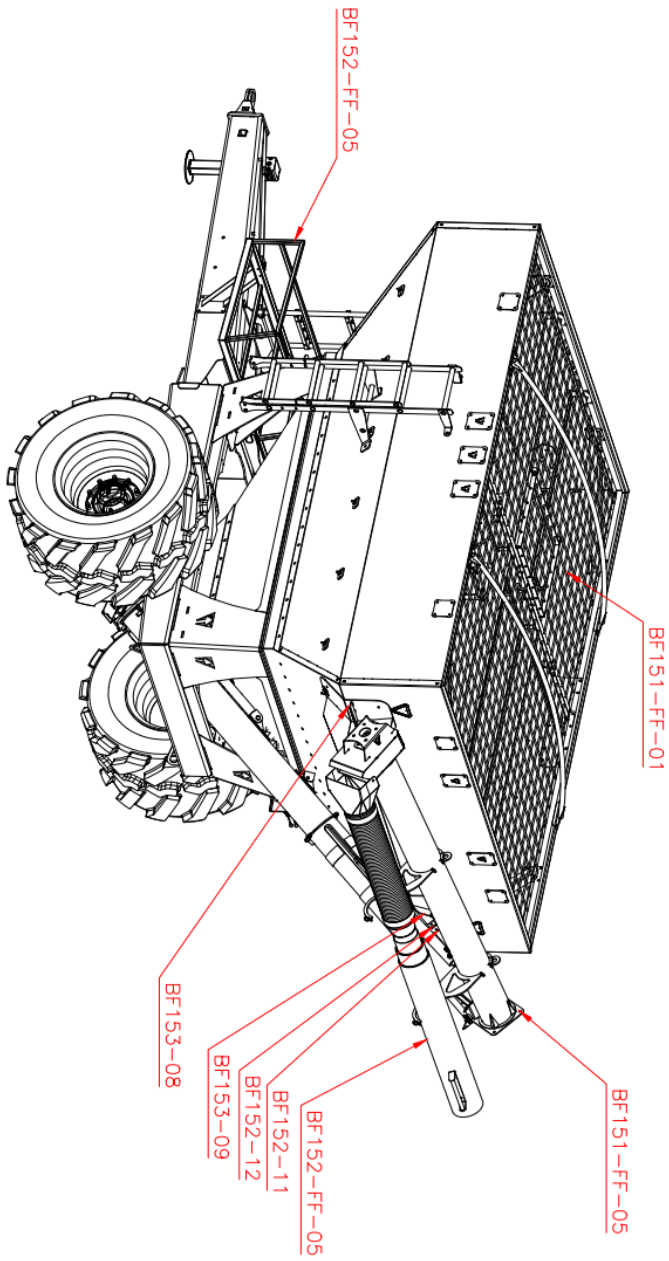

Bin & Chassis Assembly - BF151-FF-01

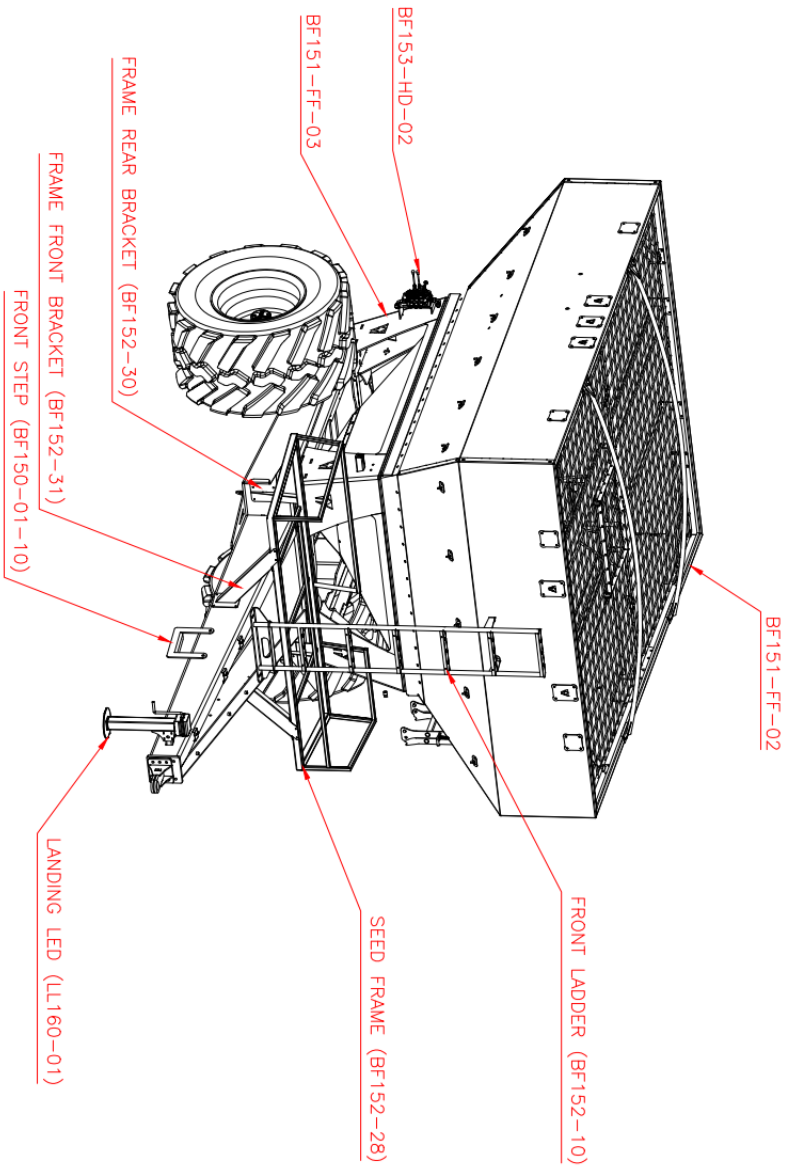

Top Bin Assembly - BF151-FF-02

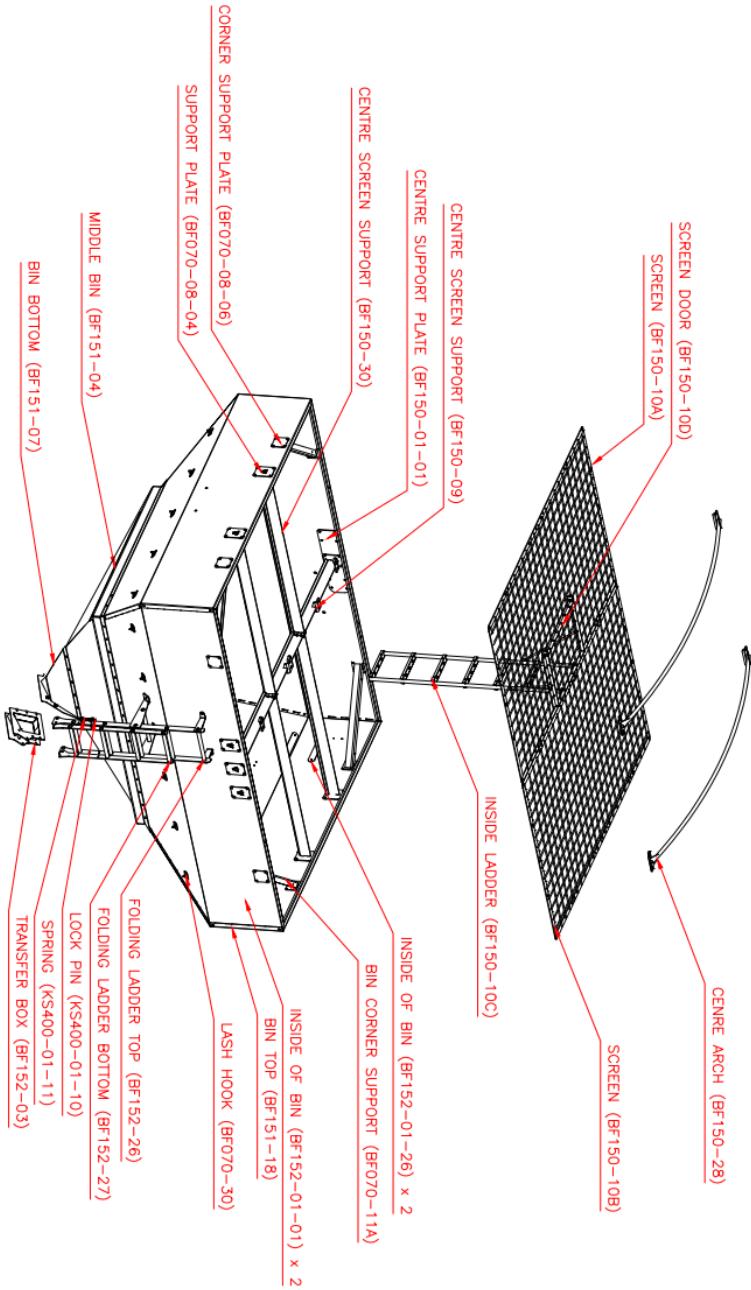

Chassis & Axle Assembly - BF151-FF-03

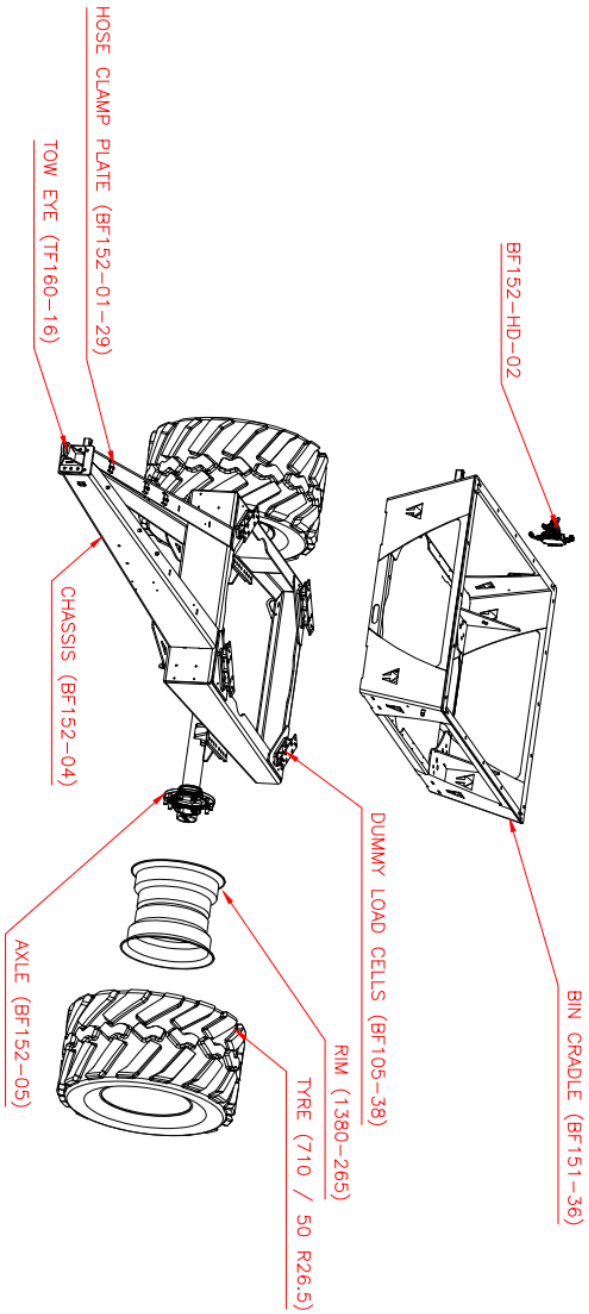

Auger Pipe Assembly - BF151-FF-05

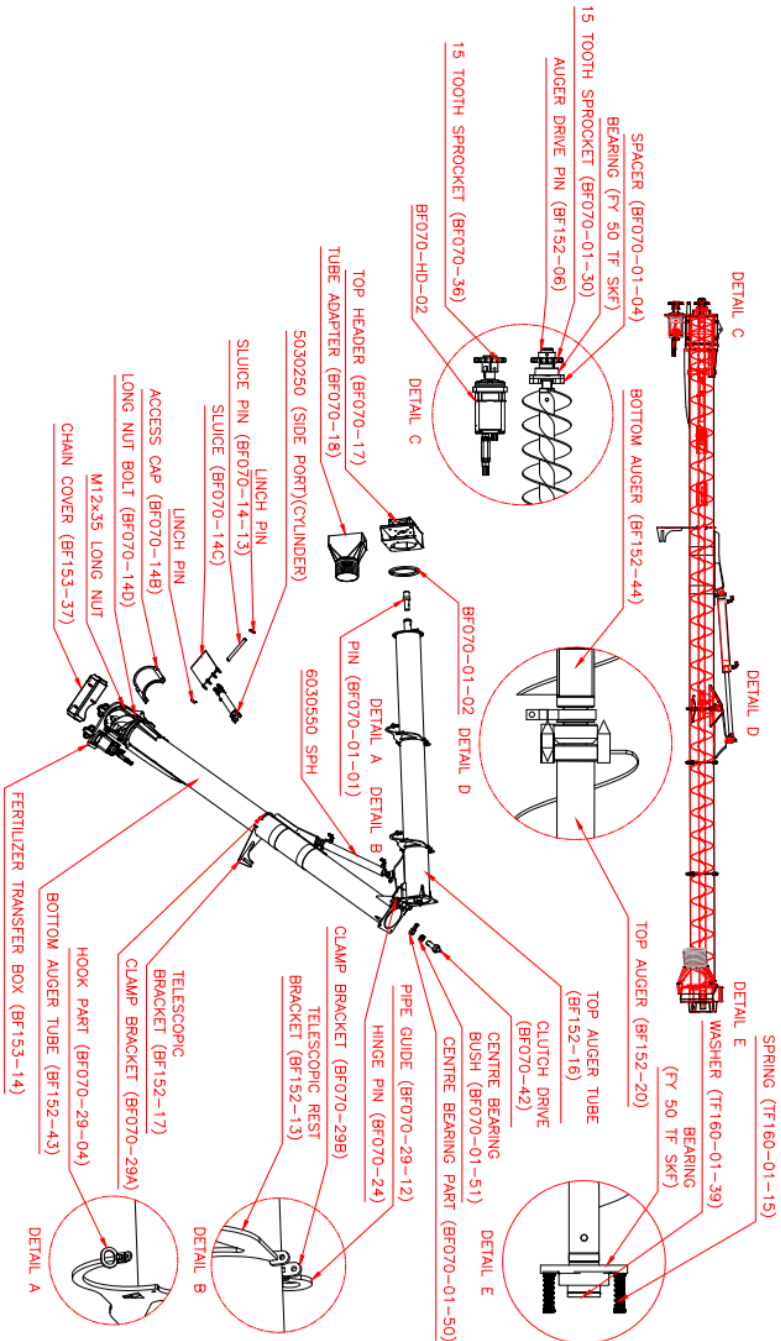

Telescopic Pipe & Control Handle - BF152-FF-06

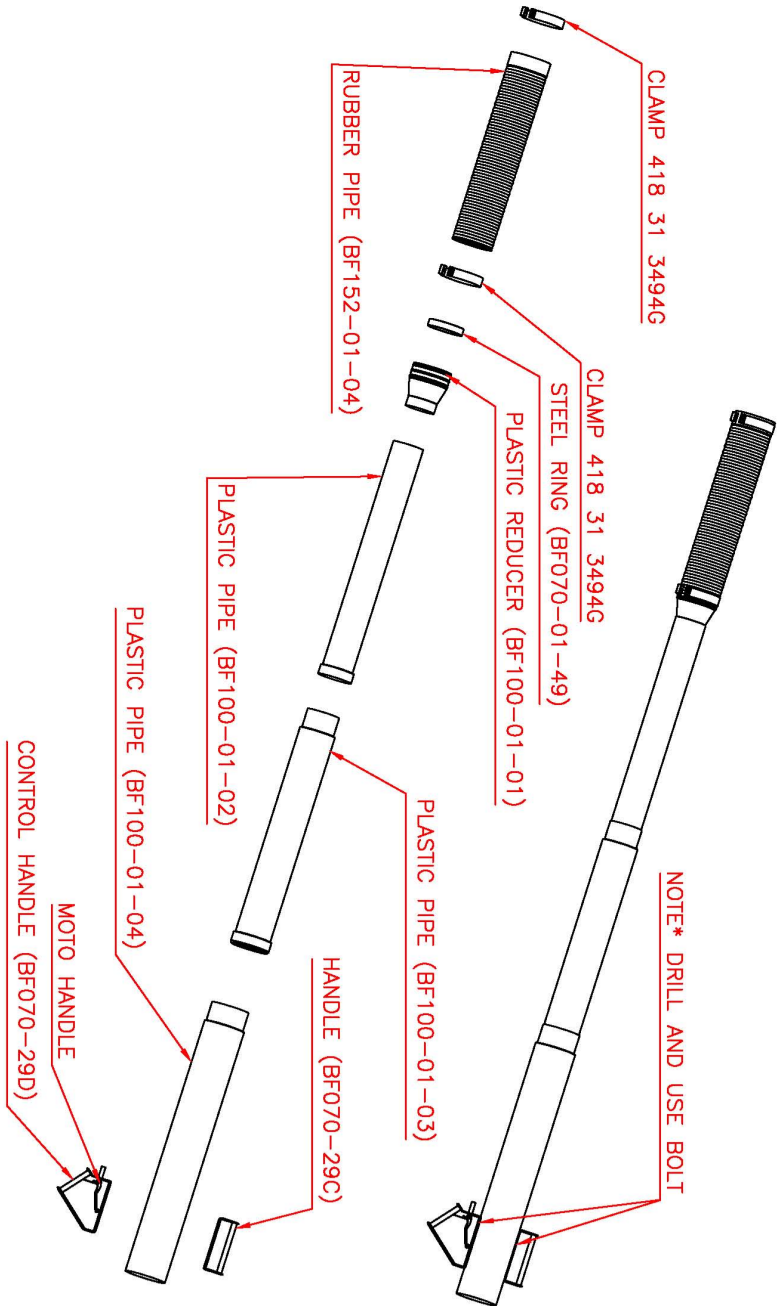

Hydraulic Pipe Layout - BF151-HD-01

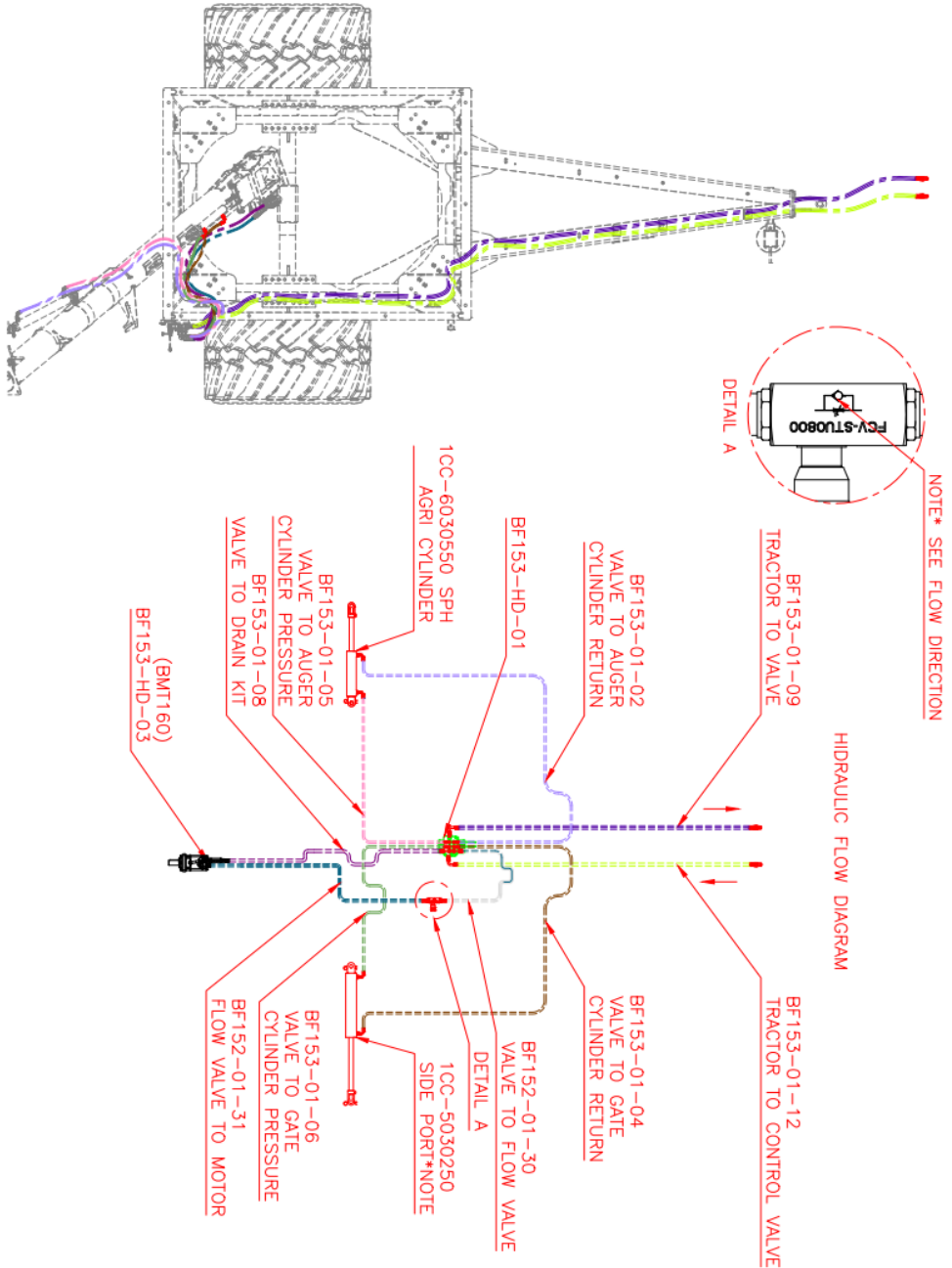

Hydraulic Valve bank - BF153-HD-01

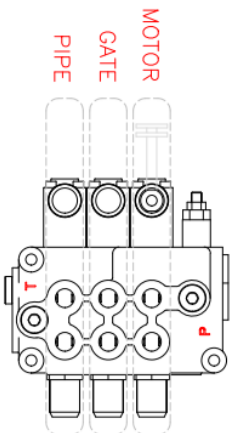
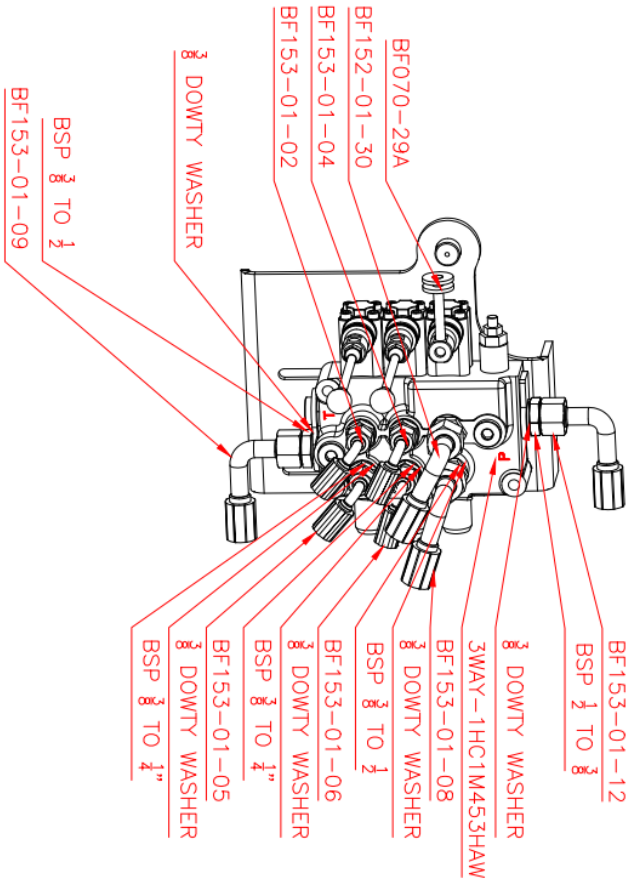

Hydraulic Motor - BF153-HD-03

ALWAYS USE HYDRAULIC SEALAND
CHECK VALVE DIRECTION IMPORTANT
AUGER TO TURN COUNTER CLOCKWISE

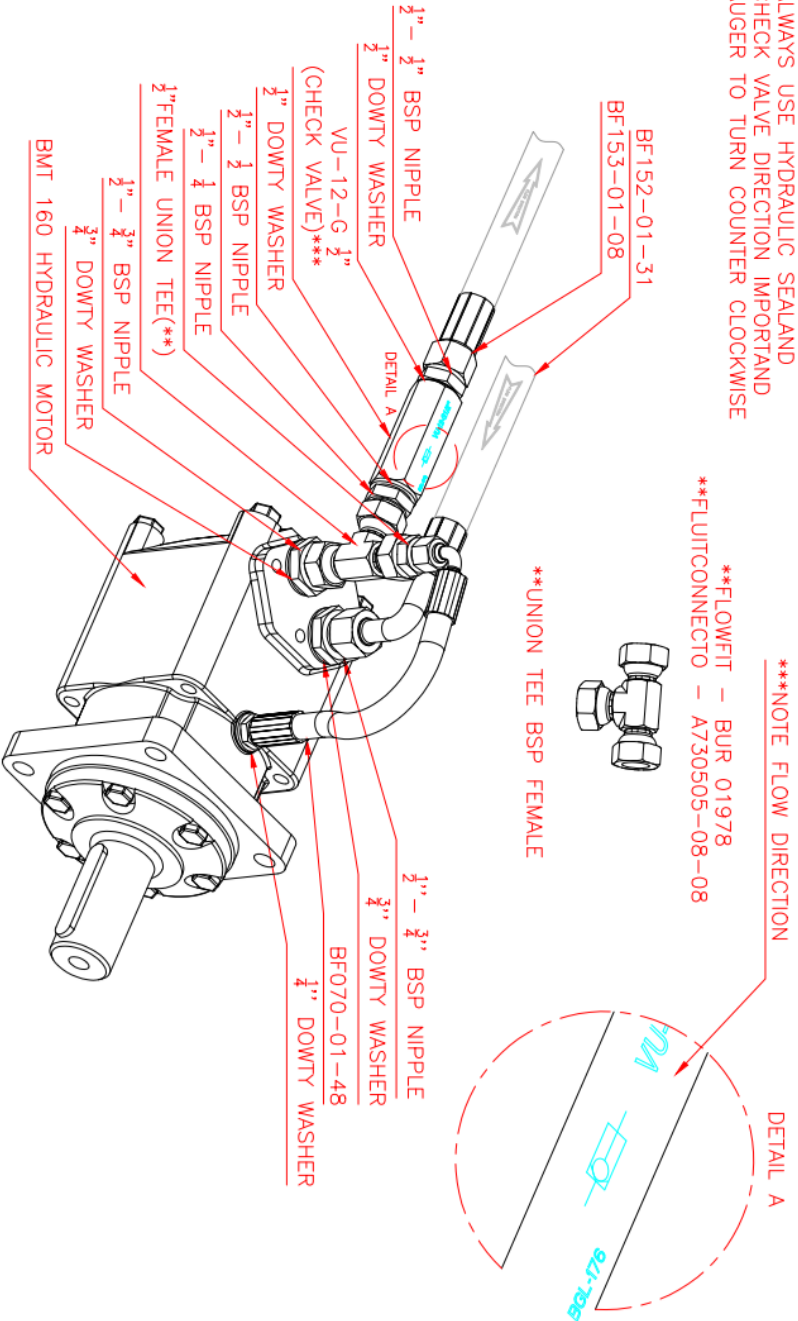

This page was left blank intentionally.



WARRANTY REGISTRATION

Dealer to complete and send to Info@agricad.co.za or fax to 0861001203

Implement:

Serial Number:

Dealer:

Customer Name:

Date of Sale:

Signature Client:

Dealer Stamp:

This implement carries a one year warranty on parts and workmanship under normal and intended use. This warranty is limited to the repair and/or replacement of defective parts.

No wear parts are covered under warranty.

This page was left blank intentionally.

Manufactured in South Africa

for African conditions by

AgriCAD Pty (Ltd)

www.agricad.co.za

For any assistance with AgriCAD spare parts please email to:

parts@agricad.co.za



AgriCAD © copyright
all rights reserved